

**MULTI-SLIDE
HIDDEN SILL STACKING
DOOR SYSTEM**

SERIES 905

INSTALLATION INSTRUCTIONS



awake
WINDOW & DOOR CO.



905 SERIES NAME

Foster care often feeds the prison pipeline.

Our Multi-Slide Door products are named the 905 Series to draw attention to the fact that 90% of foster kids that have 5 or more home placements in their lifetime will end up in the justice system. Our prison system is often full of young people that had extremely difficult upbringings, and prison is rarely the method or place to rectify this. Awake partners with organizations and actively looks to employ at-risk young men and women aging out of the foster care system to help them build a career and avoid the prison cycle. By simply using a 905 series multi-slide you are a part of the solution.



MULTI-SLIDE STACKING SYSTEM

Series 905 Multi-slide non-pocket door systems are custom manufactured per ordered specifications. It is important that you carefully review and understand the installation instructions and any drawings supplied for your project prior to the installation of any products. Disregarding or failing to follow these written instructions may result in the inferior performance of your newly installed product including, but not limited to water intrusion, failure, improper operation, and security issues, and may void Awake Window & Door Company's limited warranties. Window products manufactured by Awake Window & Door Company should only be installed by experienced and qualified installation professionals. Refer to Awake's product safety guidelines before handling, moving, offloading, or installation of awake products.



STORAGE AND HANDLING

Upon delivery of your Awake Window & Door Company products, confirm that there is no damage that will affect the appearance or performance of the installed product. The components required and supplied within the hardware box kits will vary depending on the configuration you are installing. Inspect the product and hardware components to become familiar with them.

Damaged and/or missing parts should be reported to your supplier immediately. If screens are

included, they will be packaged separately and are to be installed after the product is finished to avoid damaging the screens.

This product must be protected before, during, and after installation to prevent damage to the frame finish, hardware, and/or glass.

Awake Window and Door manufactured products are to be kept in the manufacturer's packaging and stored in a dry location protected from the elements until ready for installation. If packaging becomes wet, remove, and immediately replace it with dry packaging or covering to prevent damage to the product.

When handling door panels, they should be transported and stored upside down to avoid damage to the bottom rail weather seals. The product shall not be dragged off any delivery truck or dropped on the floor during storage. Products should only be lifted/moved with glass cups attached directly to the glass and should not be lifted or dragged by the frame, which can cause damage. Damage caused by improper handling and/or storage is not covered by Awake Window & Door's limited warranty.



PREPARATION

Always dispose of or recycle any removed door materials properly. For more information, check with your local recycling agency, the U.S. Environmental Protection Agency ("EPA"), or Build Reuse to locate a nearby company or organization that accepts used windows and doors.

CAUTION: Many homes built before 1978 may have been painted with lead-based paint. Removal of old doors may disturb this paint. Proper precautions must be taken to minimize exposure to dust and debris. Consult state or local authorities and/or [the EPA](#) for more information.

Verify that the number of doors ordered have been received and are manufactured to the specified size and configuration. Inspect and verify the rough opening for the product which you are installing is plumb, level, and approximately 1/2" bigger in width and height than the net frame size.

Measure and inspect flooring to ensure it is flat and level. If the floor varies more than 1/16" (.062") per 60-inch span or a total of 1/4" (.25") over the span of the opening width, it must be corrected prior to installation of the door.

You may need to supply:

- Moisture-resistant shims/spacers.
- Flashing membrane and compatible sealant.
- Fasteners
 - 3/16" Tapcon concrete anchor screws. (Sill concrete anchoring)
 - #10 x 2" PH Flat Head screws (Block Frame install application)
 - #10 x 5/8 PH Flat Head screws
 - #10 x 1" PH Flat Head screws
 - #8 x 1" PH Flat Head screws
- Closed cell foam backer rod/sealant backer
- 1/2" male NPT to 1/2" hose bard fittings
- 1/2" inside diameter flexible vinyl tubing
- Sill pans, structural adhesive, and drains.

NOTE: All materials used in the installation shall be of good quality and shall be free of defects that would diminish the appearance of the product or render it structurally or operationally unsound. Installation includes the furnishing of any equipment, rigging, and materials required to install or replace the product in the proper location.

Tools required for Installation:

- Tape Measure
- Levels of various sizes
- Laser level (if needed)
- Plumb bob
- Utility Knife
- Sealant Gun
- Screw gun with
 - o #2 Phillips Driver bit
 - o #2 Square Drive
- Pry bar
- 5 in 1 Putty knife
- Dead-blow rubber mallet
- Quick Clamps
- Suction Glass Cups
- Drill with
 - o 3/16", #21 drill bit
 - o #10 Countersink bit.

Note: Other construction materials may be required. Read the following instructions carefully and inspect the wall conditions before you begin.

Frame Components:

The perimeter frame shall consist of one (1) head and sill assembly, two (2) jamb assemblies, two (2) jamb fillers, and two (2) hardware box kits. The sill assembly is comprised of a lower sill section and an upper stone holder section.

If the total frame width exceeds 240" (20'-0") the head and sill assemblies will be supplied in two (2) or more sections to be sealed and joined during installation.

Panel components:

Unless noted otherwise, panel components may contain one or more of the following options:

Standard doors:

- one (1) or two (2) active lead panels (contains lock and handle assembly)
- one (1) or several intermediate panels
- one (1) or several fixed panels
- one (1) or several screen panels

Bi-parting stacking doors:

- one (1) active lead panel (contains lock and handle assembly)
- one (1) in-active lead panel
- one (1) or several intermediate panels
- one (1) or several fixed panels
- one (1) or several screen panels

If a bi-parting door is requested, you will have one (1) active lead panel and one (1) inactive lead panel. The active panel will be installed to the left of center, as viewed from the exterior of the building.



FRAME INSTALLATION

1. Refer to the shop drawings and inspect the rough opening carefully to ensure has been prepared correctly to accept the width, height, and depth of the door you are installing.
2. If the door frame is to be set on a wood substrate, the wood must be protected with an appropriate flashing or waterproofing membrane prior to door frame installation.
3. Measure and inspect the surface the sill will be supported by. Ensure it is flat and level. If the Surface varies more than 1/16" (.062") per 120-inch span or a total of 3/16" (.188") over the span of the opening width, it must be corrected prior to installation of the door. The sill should be supported by placing shims a minimum of every 6". Failure to adequately install the sill may result in operational issues that may require re-installation of the sill.
4. All holes needed for installation must be drilled into the frame prior to the caulking, sealing, and setting of the frame. Pre-drill required installation holes with a 3/16" drill bit as follows:
 - Frame Head - holes should be drilled 12" from each end and every 24" on center per track. See **Figure 1**. Sill - holes should be drilled 6" from each end and every 24" on center per track. See **Figure 2**.

- Jamb - holes should be drilled 12" from each end and every 24" on center per track. See **Figure 3**.

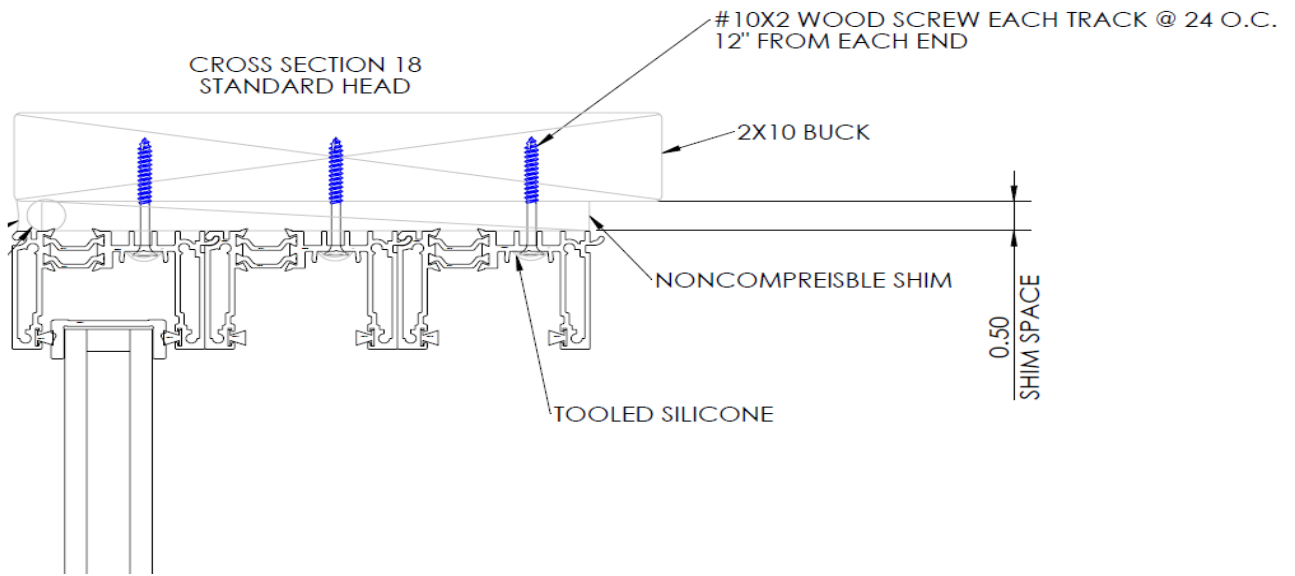

Figure 1

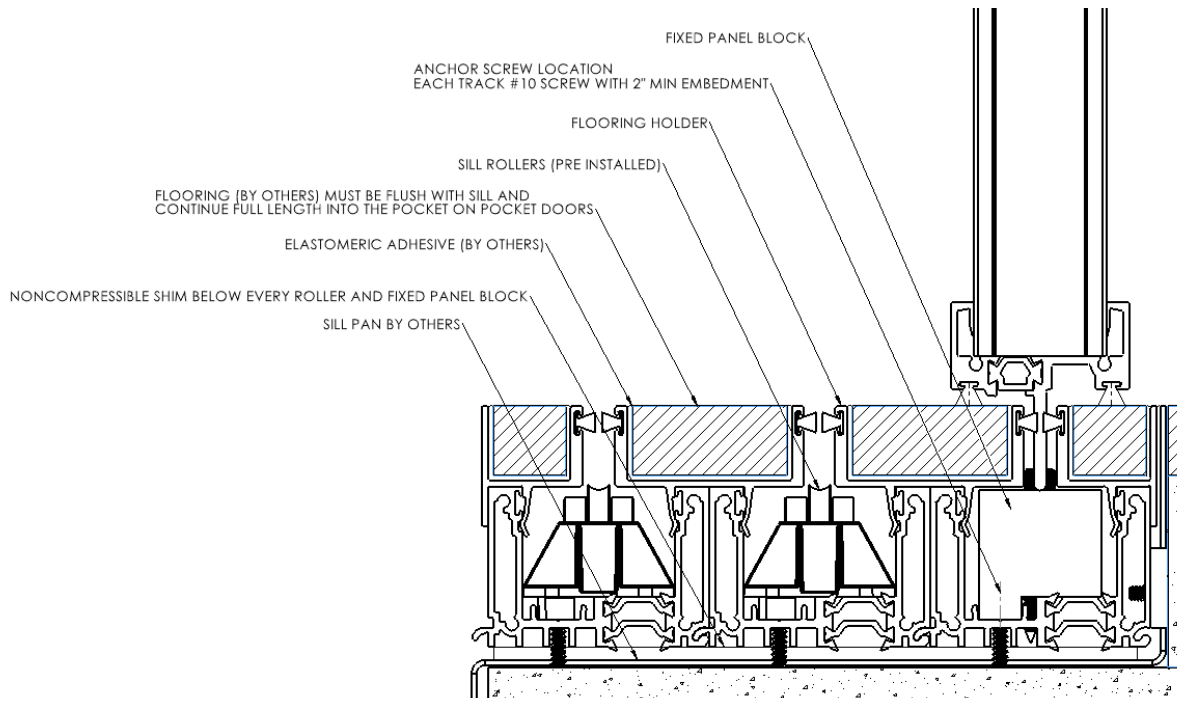

Figure 2

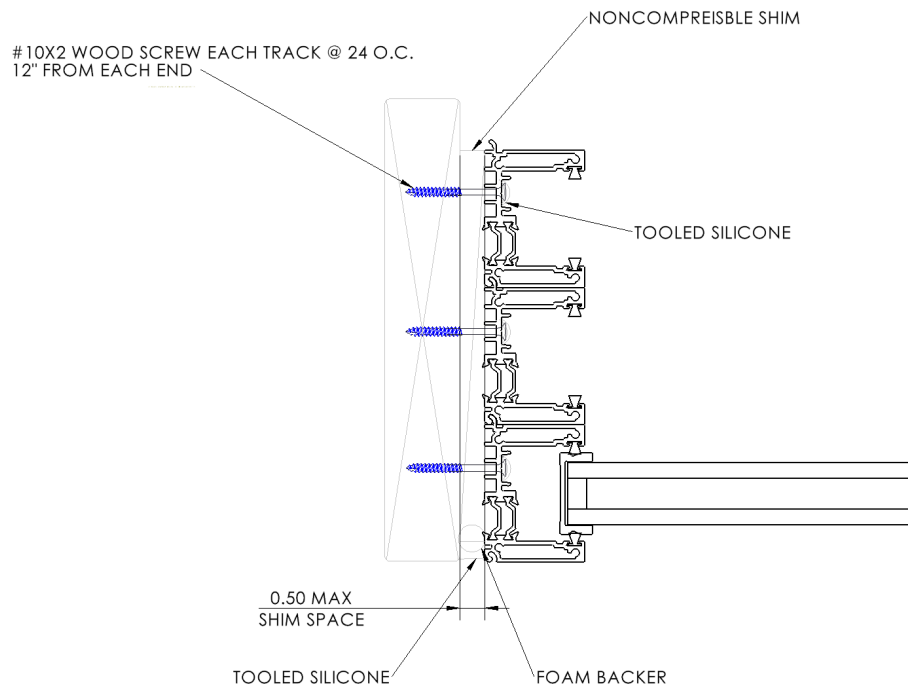

Figure 3

5. Depending on the type of sill option you are installing, the hidden sill can have one of the following four water management systems or no water management:
 - Bottom Drain Fitting Sill (See **Figure 4**)
 - Side Drain Fitting Sill (See **Figure 5**)
 - Front Weep with pan and drain by others (See **Figure 6**)
 - Front weep with deck drain and pan by others (See **Figure 7**)
 - No water management (sill with no weeps or drain fitting) (See **Figure 8**).
6. Skip to the appropriate step for the sill you are installing. For the Bottom Drain Fitting Sill, proceed to step 6. For the Side Drain Fitting Sill, skip to step 7. For either Front Weep option, skip to step 8. For the no water management sill, skip to steps 9.
7. **Bottom Drain Fitting Sill** - the Bottom Drain Fitting Sill option will require clearance below the sill at the drain fitting locations to accommodate the drain fittings and associated drain tubing. See your supplied shop drawings for the location of these fittings on the underside of your sill.

NOTE: pocketing doors should not have drain fittings or weeps located in the pocket area of the sill. Be sure to leave adequate clearance for a drain line and fitting for each track. See Figure 4.

Connect ½" NPT pipe to ½" hose barb fittings using tread sealant or Teflon tape to the drain fittings attached to the bottom of the sill. Push fully the ½" minimum inside diameter hoses onto the barbed fittings and route to an appropriate drainage location, ensuring that the hoses have a continuous downward slope of at least ¼" per foot. Skip to step 10.

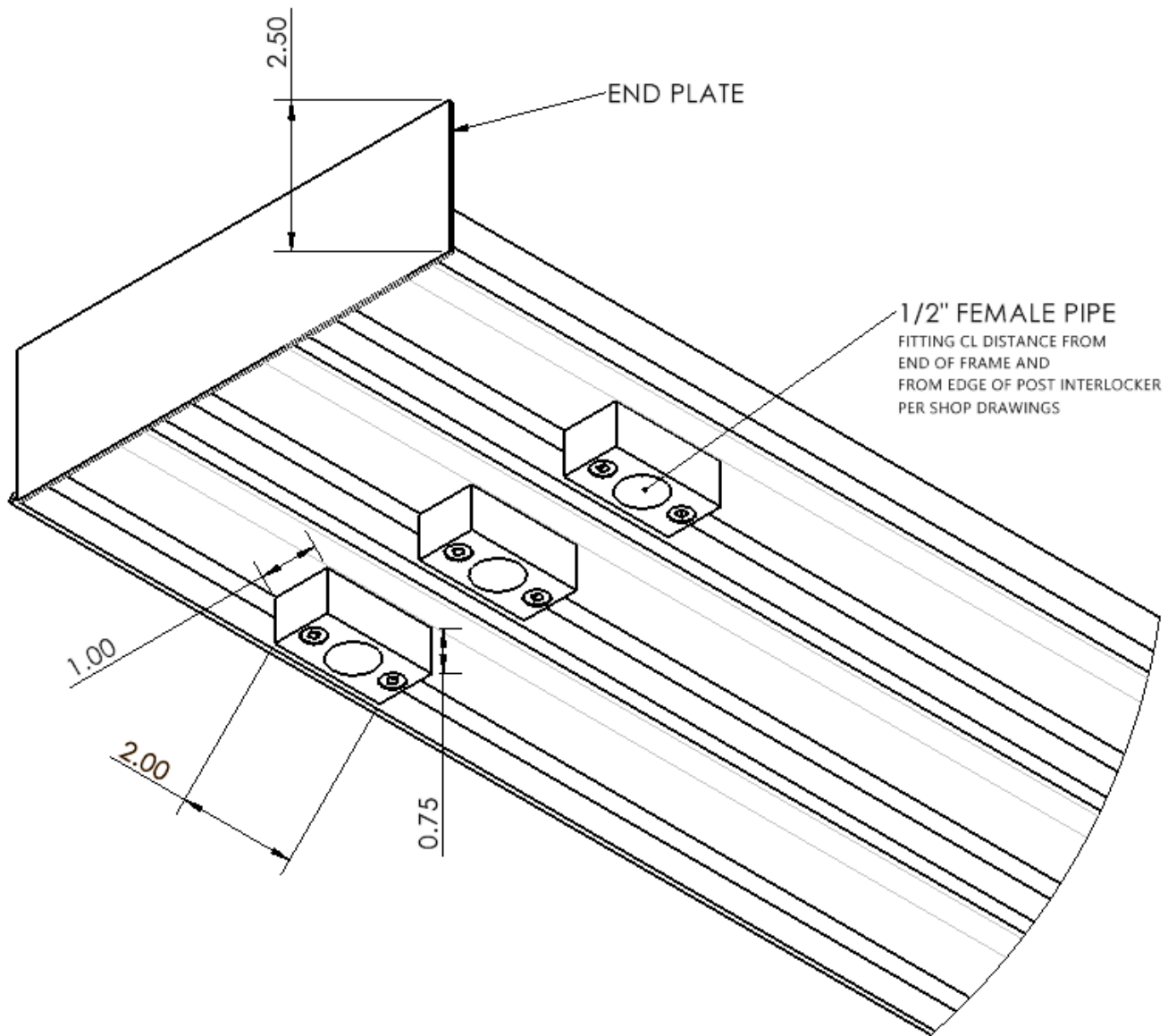

Figure 4

8. **Side Drain Fitting Sill** - The Side Drain Fitting Sill option will require clearance at each end of the sill to accommodate 1/2" NPT pipe to barbed hose fittings and associated drain tubing. Be sure to leave adequate clearance for a drain line and fitting for each track. Staggered tracks will have a drain line at each stagger location.

Screw the 1/2" NPT pipe to 1/2" hose barb fittings using tread sealant or Teflon tape to the ends of each track. Push fully the 1/2" minimum inside diameter hoses onto the barbed fittings and route to an appropriate drainage location, ensuring that the hoses have a continuous downward slope of at least 1/4" per foot. See **Figure 5**. Skip to step 10.

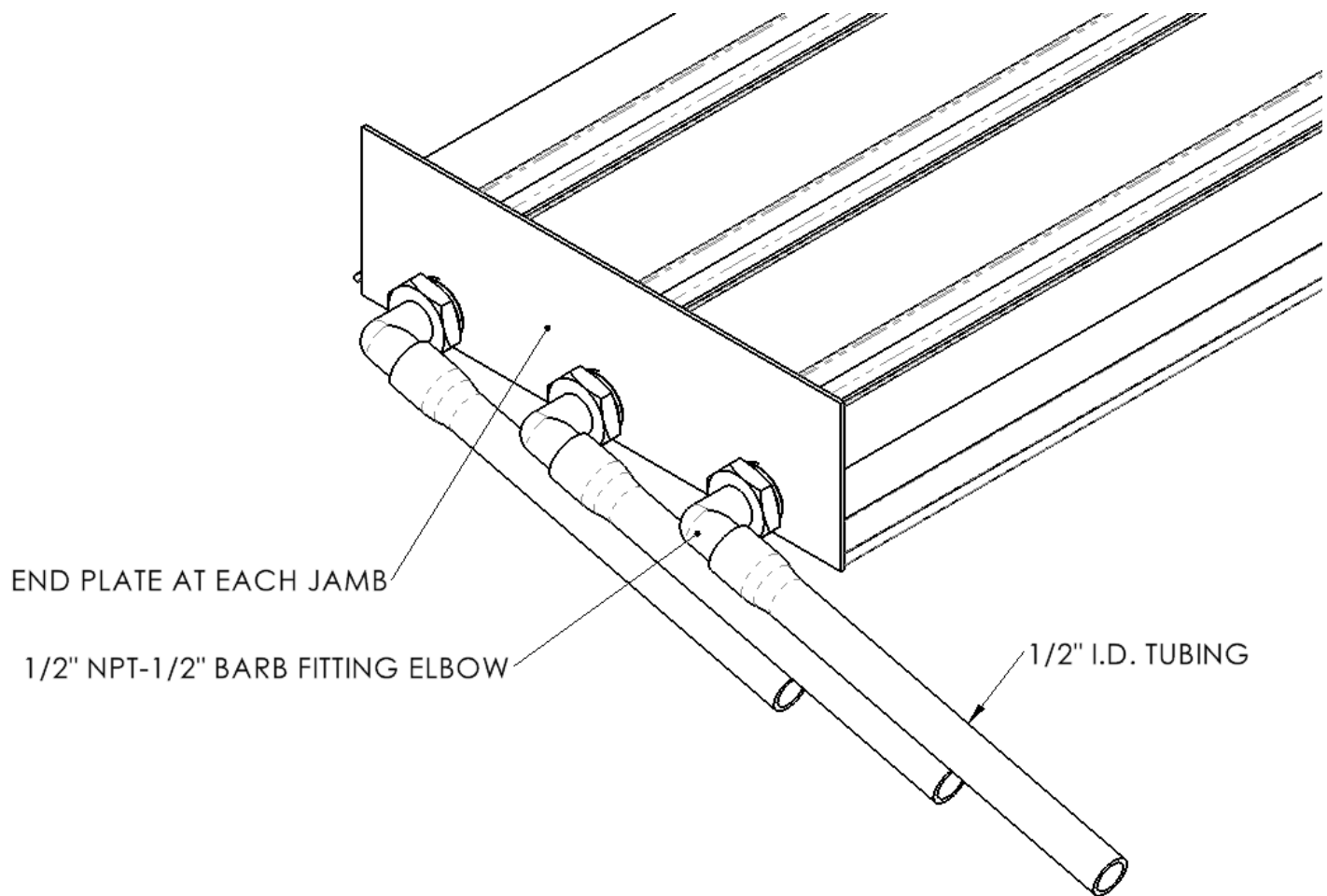

Figure 5

- 9. Front Weep Sills** - Sills that have a weep slot located on the bottom surface 6" from each end and 6" from each stagger location will allow water to drain out the bottom of the sill directly into a water management system supplied by others, such as a sill pan or equivalent. See Figure 6. If a slot drain or similar system is used, the door sill pan can be drained into the slot drain. Ensure that the slot drain bottom is adequately below the sill pan to ensure water only flow away from the sill. See **Figure 7**. Skip to step 10.

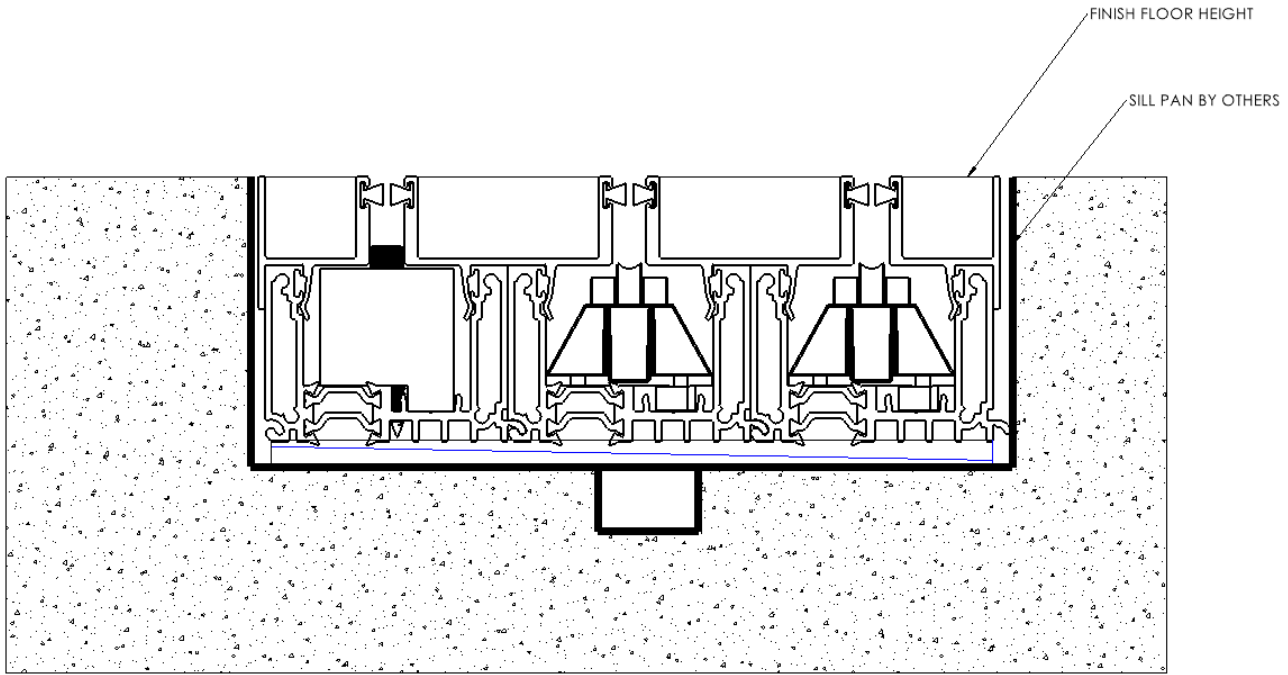

Figure 6

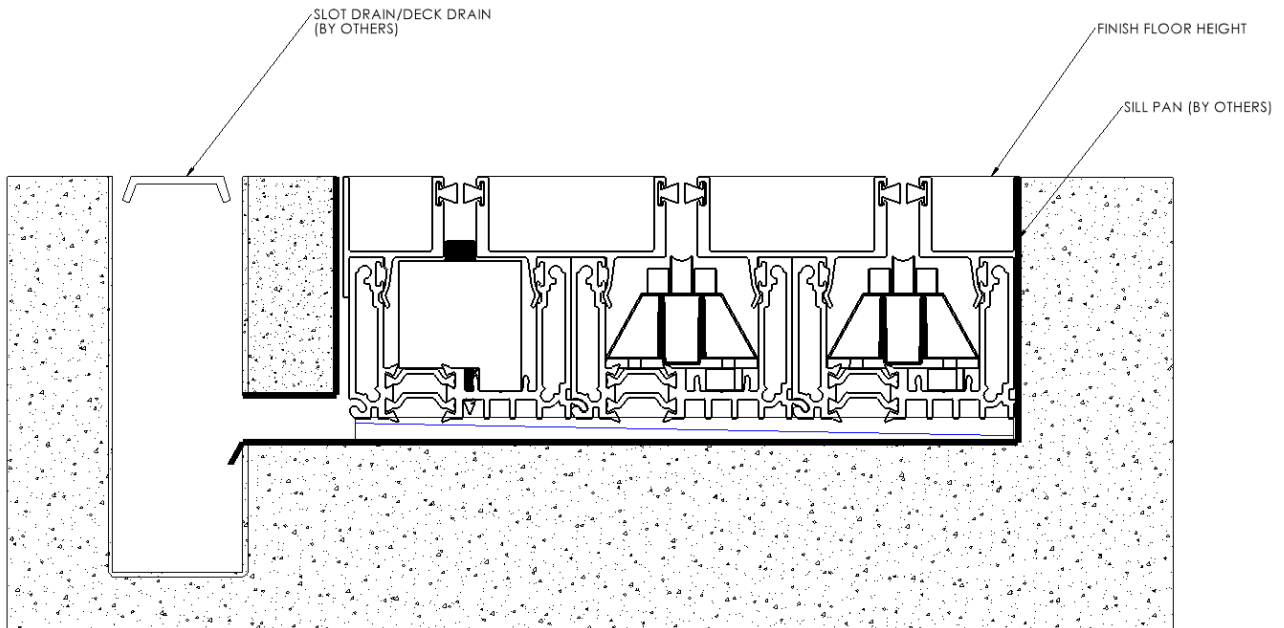

Figure 7

NOTE: Sill types with limited water rating, no water rating, or no water management should only be used in well-protected areas where a roof overhang will prevent driving rain and the exterior finish grade is stepped down and/or sloped away from the sill to help prevent water penetration. See Figure 8. Proceed to Step 10.

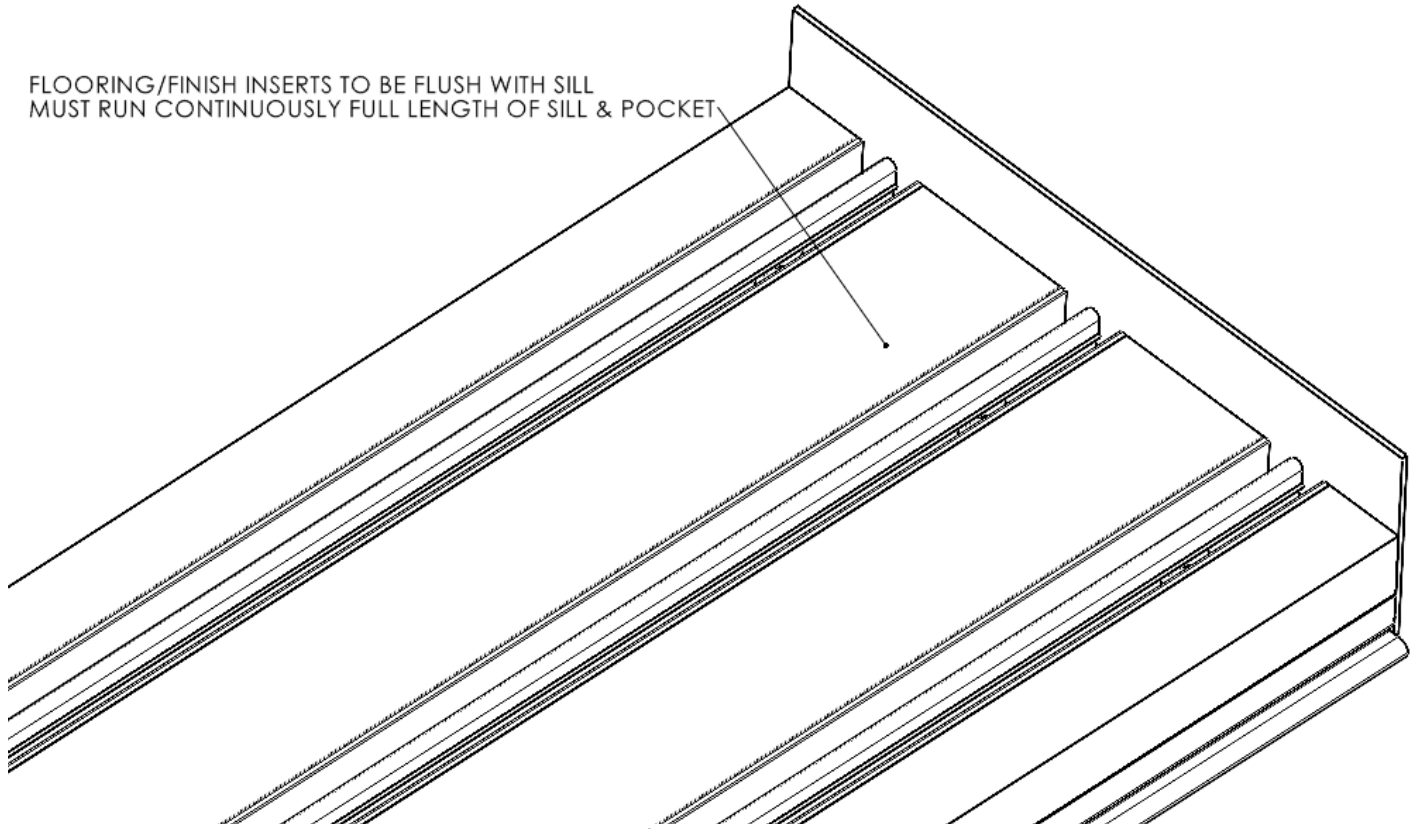
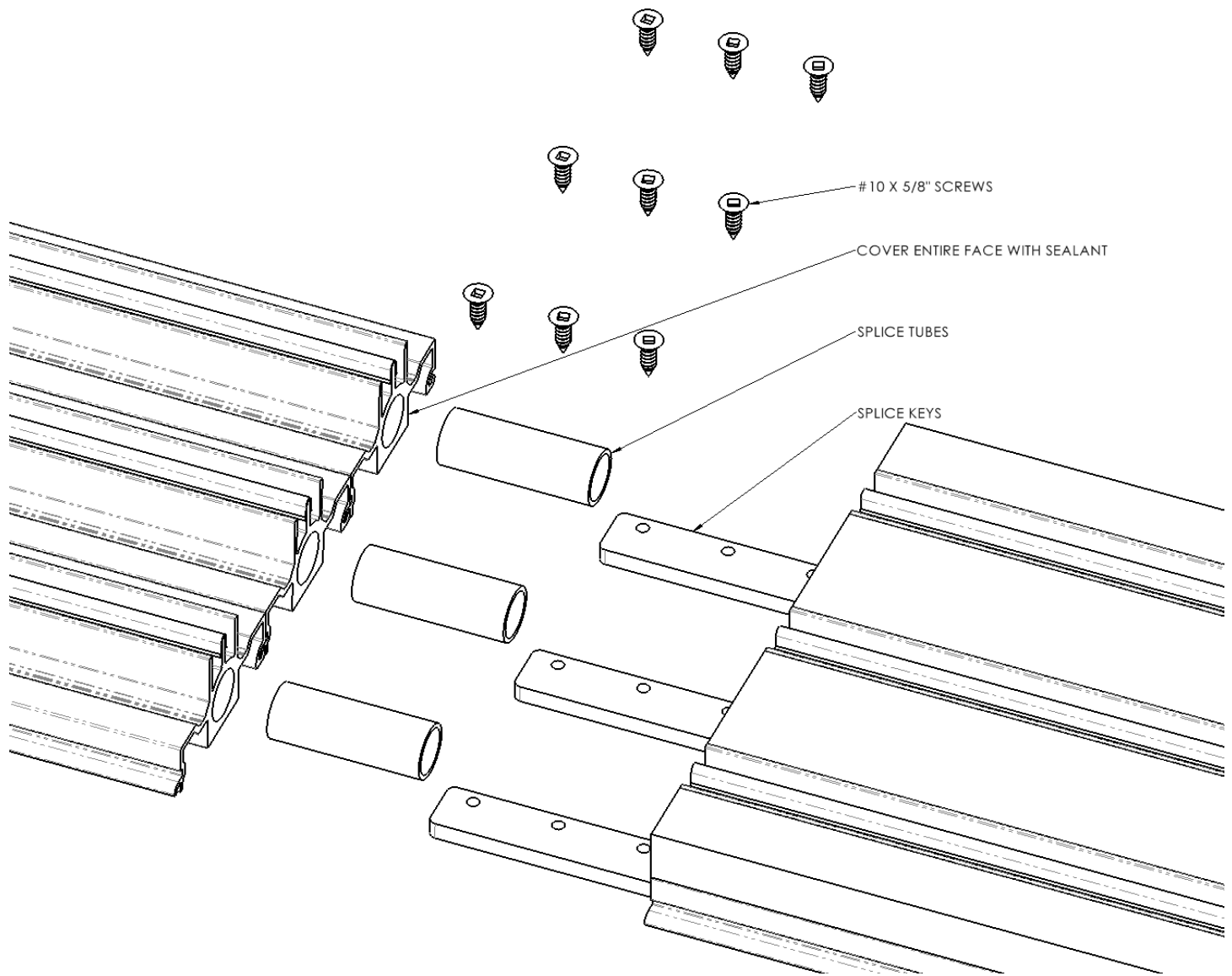

Figure 8



9. For all sill installations, inspect the sill where it encounters the surface of the floor. Inspect and mark any gaps that will need to be shimmed, filled or humps removed prior to final installation. The final installation requires that the sill be level and supported across the full span for proper operation.

10. Once the sill is in the correct location, inspect the header above to confirm that the frame head can be installed directly above the sill at the proper height as required. If no correction is to be made to the frame, mark the inside edge of the frame sill full-length to ensure the correct location and positioning when anchoring.

11. Begin to mark the flooring through each hole that was previously drilled to anchor the frame to the rough opening. Start from the exterior left side and mark every hole to the right until complete. Remove the sill and prepare the opening.

12. If the door is being set on concrete, use the appropriate drill for minimum of 3/16" Tapcon anchor screws.

Note: If you choose to drill the anchor holes into the concrete while the sill assembly is still in place, you must vacuum the debris from the top of the sill as well as from below to ensure that the sealant does not get contaminated.

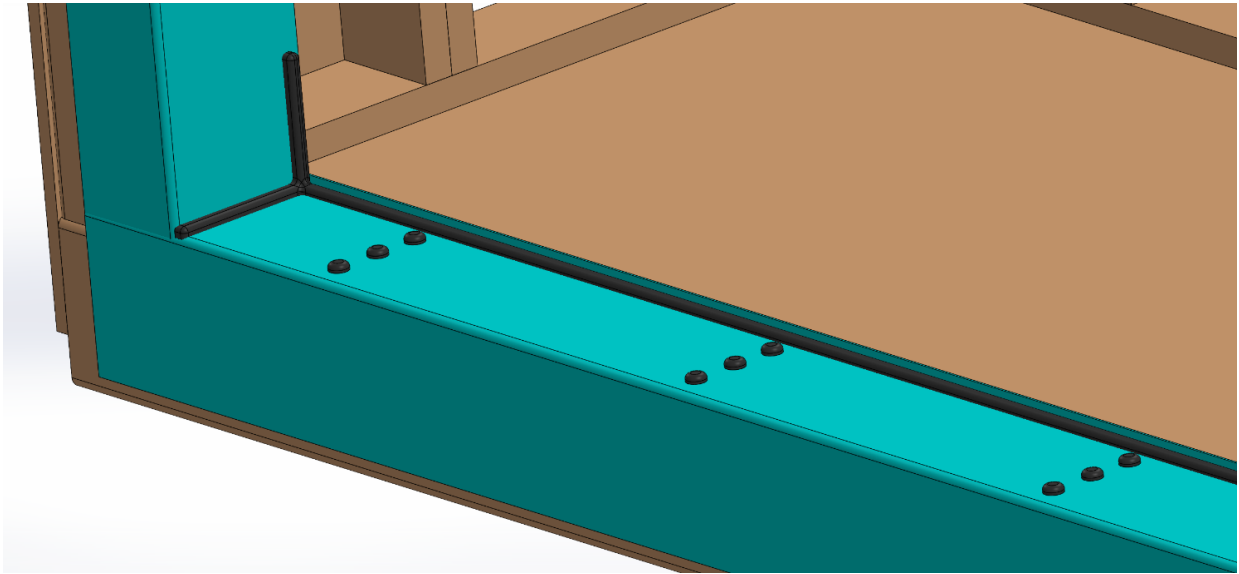

Figure 9

13. If the floor is wood with a waterproofing membrane or flashing applied, apply a generous amount of Dow 795 sealant or compatible sealant at each mark where an installation anchor screw will penetrate the waterproofing.
14. With the sill assembly removed, and clean from debris, apply a 1/2" bead of sealant to the floor from jamb to jamb along the exterior edge of the mark previously applied to the floor. The sealant should be applied in a U-shape to ensure a proper and complete water-barrier has been accomplished across the full width of the sill opening. Sealant should also be applied a minimum of 6" up each side. See **Figure 9**.
15. Set the sill assembly onto the bed of sealant and align the sill with marks on the floor. Shim the sill assembly as required and secure the frame with adequate anchor screws for your application. Once the sill is anchored to the floor, verify that it is 100% flat and level in all directions. After verification, tool silicone over the heads of all anchor screws and smooth until flush.

Note: If only securing the sill with a compatible structural adhesive, then appropriate engineering analysis must be completed to ensure adequate load-carrying capacity.

16. Snap the Flooring Holder extrusions onto the lower half of the sill with a block of wood and a hammer. Place the block of wood between the vertical legs of the flooring holder to avoid damage. Start at one end of the extrusion and slowly work down the length of the whole sill to avoid bending the flooring holders. The flooring holders can be ordered long to allow them to be cut to shorter lengths at installation to allow for easier service based on flooring types. See **Figure 10**.

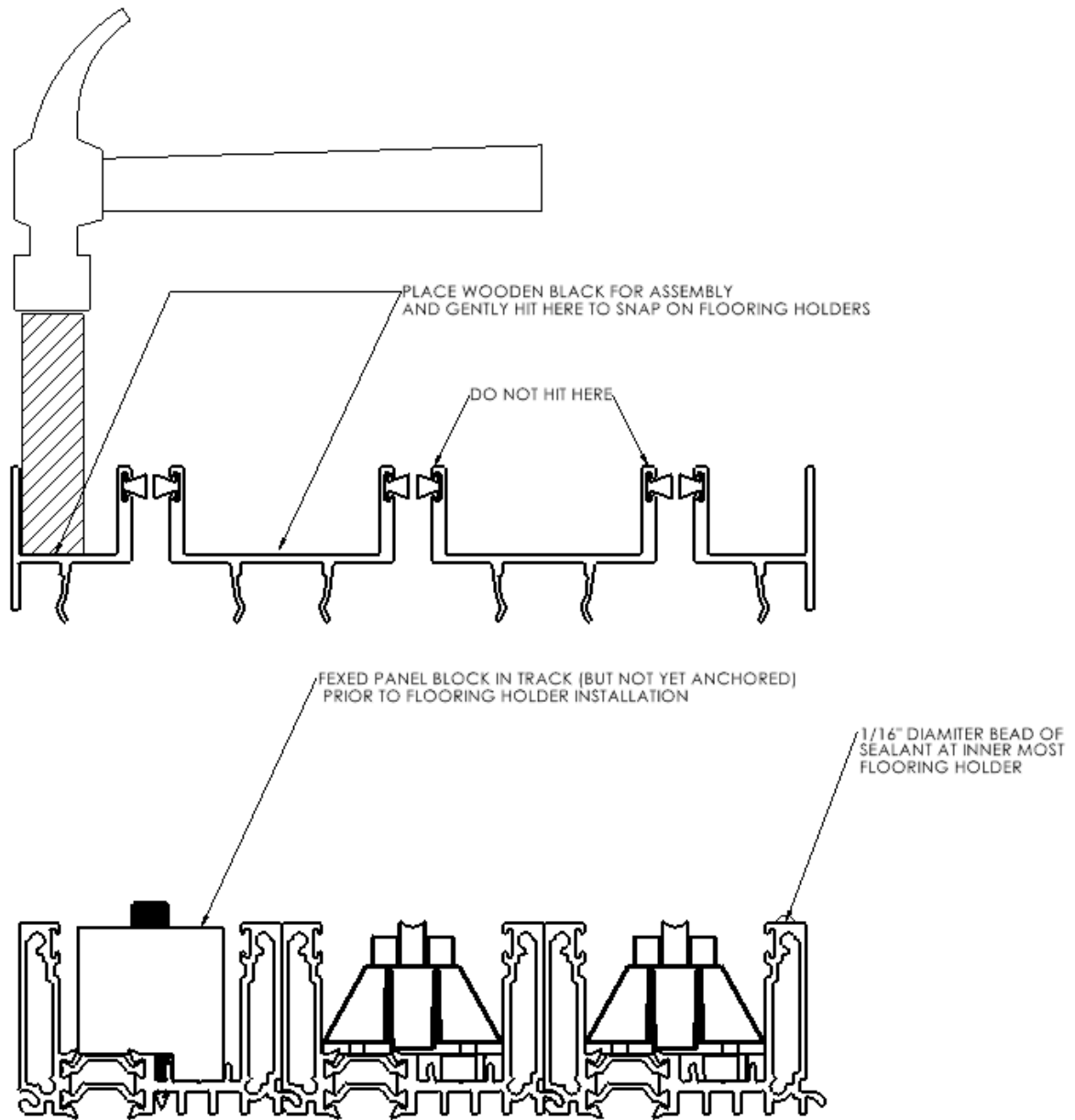

Figure 10

17. Measure and inspect the header of the rough opening to ensure that the frame head and jamb assemblies will fit with sufficient backing (3/4" thick plywood or 1.5" thick dimensional lumber minimum) for anchoring. Based on your net frame size as indicated by your drawings or purchase order, ensure whether additional material needs to be added to the header prior to installation to minimize excessive shimming.
18. Using a plumb bob or laser level, mark several points onto the header framing to align and position the head assembly parallel to the sill assembly. With assistance, carefully raise the head assembly onto the framing header and secure it temporarily with #10 x 2" PH Flat head screws as needed to hold the head assembly safely in place.

19. Locate and set each jamb between the sill and the head assembly. Set the jamb in place and ensure it is in line with the head. Ensure the sill is plumb and level. Raise or lower the head assembly to align with the jamb as needed. Once set in place, secure the jamb to the rough opening temporarily with #10 x 2" PH Flat head screws as needed to hold the jamb safely in place.
20. Pre-drill the jamb to the endplate assembly holes at each end and as required with a #21 drill bit. Remove the jamb assembly and seal the jamb to the endplate interface at the sill location with Dow 795 sealant. See **Figure 14** a & b.

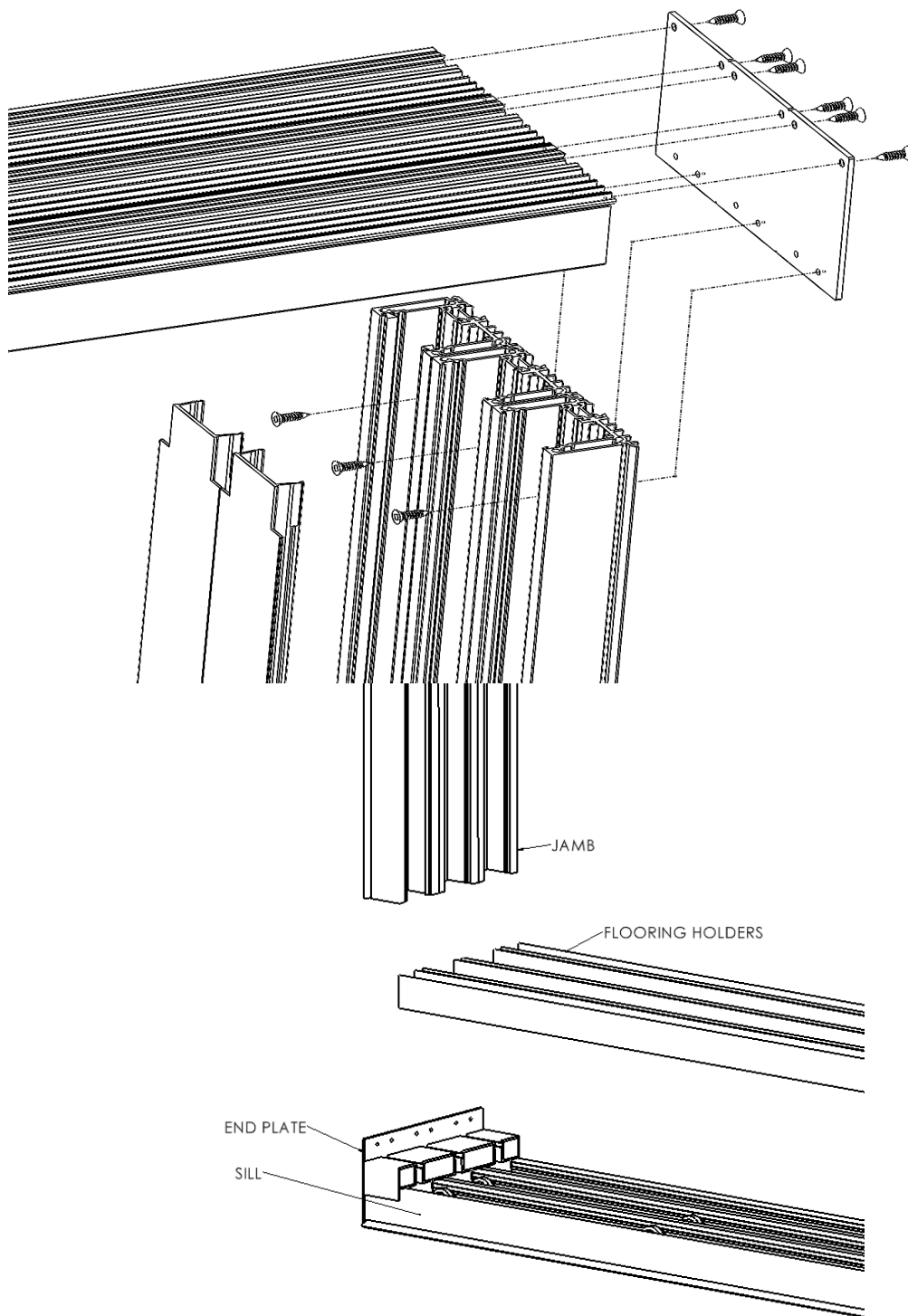

Figure 11

21. Reinstall the jamb assembly and secure to the frame head and sill with #10 x 1" Ph Flat Head screws. Shim as needed and continue to secure the jamb to the rough opening with #10 x 2" PH Flat head screws through remaining holes.
22. Complete the anchoring of the frame head assembly to ensure it is flat, level, and parallel

with the sill assembly. Identify and apply all snap-in beauty covers to conceal the anchor screws and create a smooth finished surface.

23. Complete the jamb assembly by locating and applying the snap-in beauty cover to the locking jamb which will be visible when the door panel is open. Continue to finish the jamb assembly by lightly tapping the remaining jamb fillers onto the jamb with a non-marring rubber mallet.



PANEL INSTALLATION AND ASSEMBLY

- Snap the fin on to the bottom of the lead panel with a soft mallet or dead blow hammer. The bottom of the panel will have the glass tempering mark “bug” located in the corner. See **Figure 12**
- For XO configurations, place lead panel at the left of the door system.
- For OX configurations, place lead panel at the right of the door system.

Figure 12

Note: If you are installing a bi-parting door, you will have one (1) active lead panel and one inactive lead panel. The inactive lead panels are to be installed on

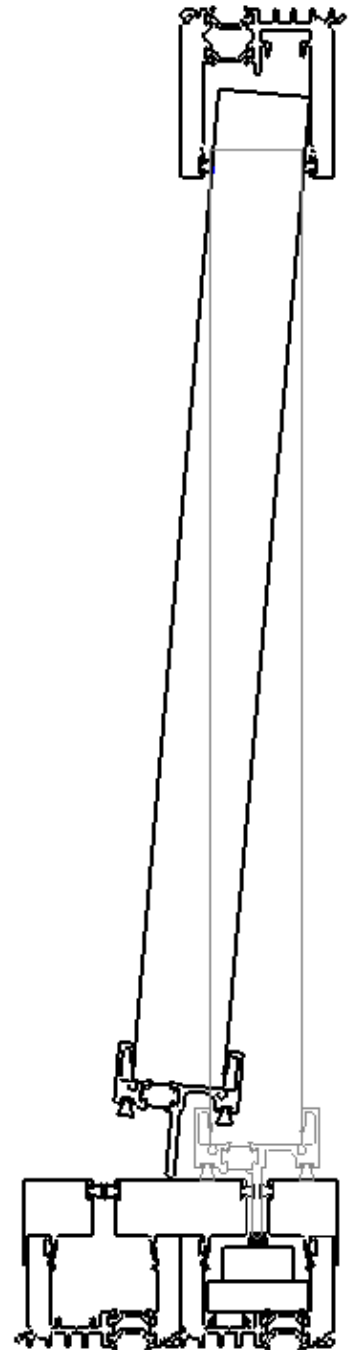

the innermost track. The active lead panel will be installed to the left of the center, as viewed from the exterior of the building. Fixed panels have one (1) interlock and rest on the outermost track. Intermediate panels will have two (2) interlock stiles.

1. From the exterior of the building lean the top of the panel into the innermost head track and lower the fin straight down into the sill assembly. See **Figure 13**.
2. Locate the stiles and/or interlockers labeled for the matching. Snap the lead stiles with a block of wood and a soft hammer. Start at the bottom of the extrusion, slowly working up to the length of the part gently “zippering” the part onto the panel. Use caution to not dent the extrusions. Secure the parts to the panel with the end sweep and (2) #10 x 2” screws. See **Figures 14 & 15**.

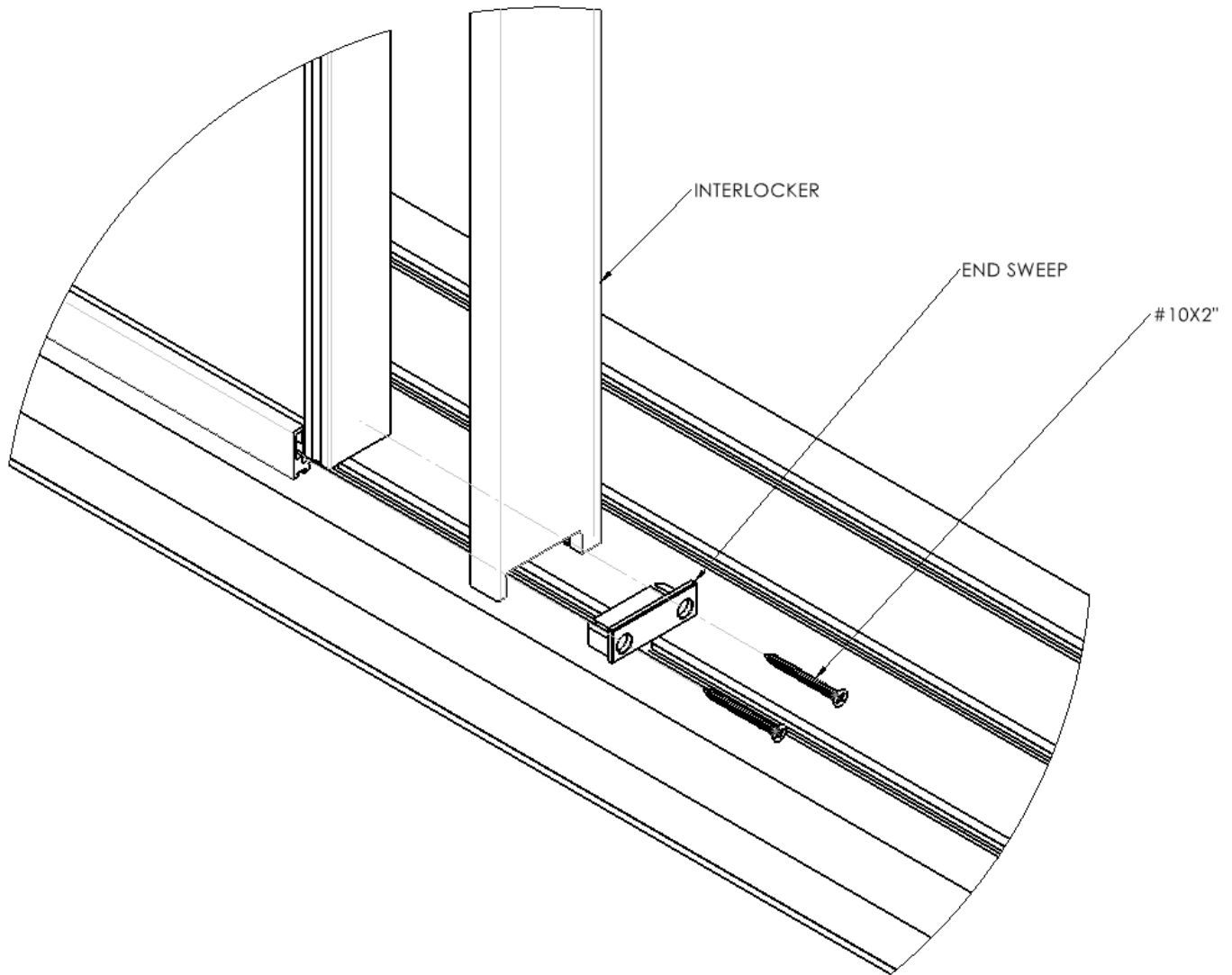

Figure 13 and 14

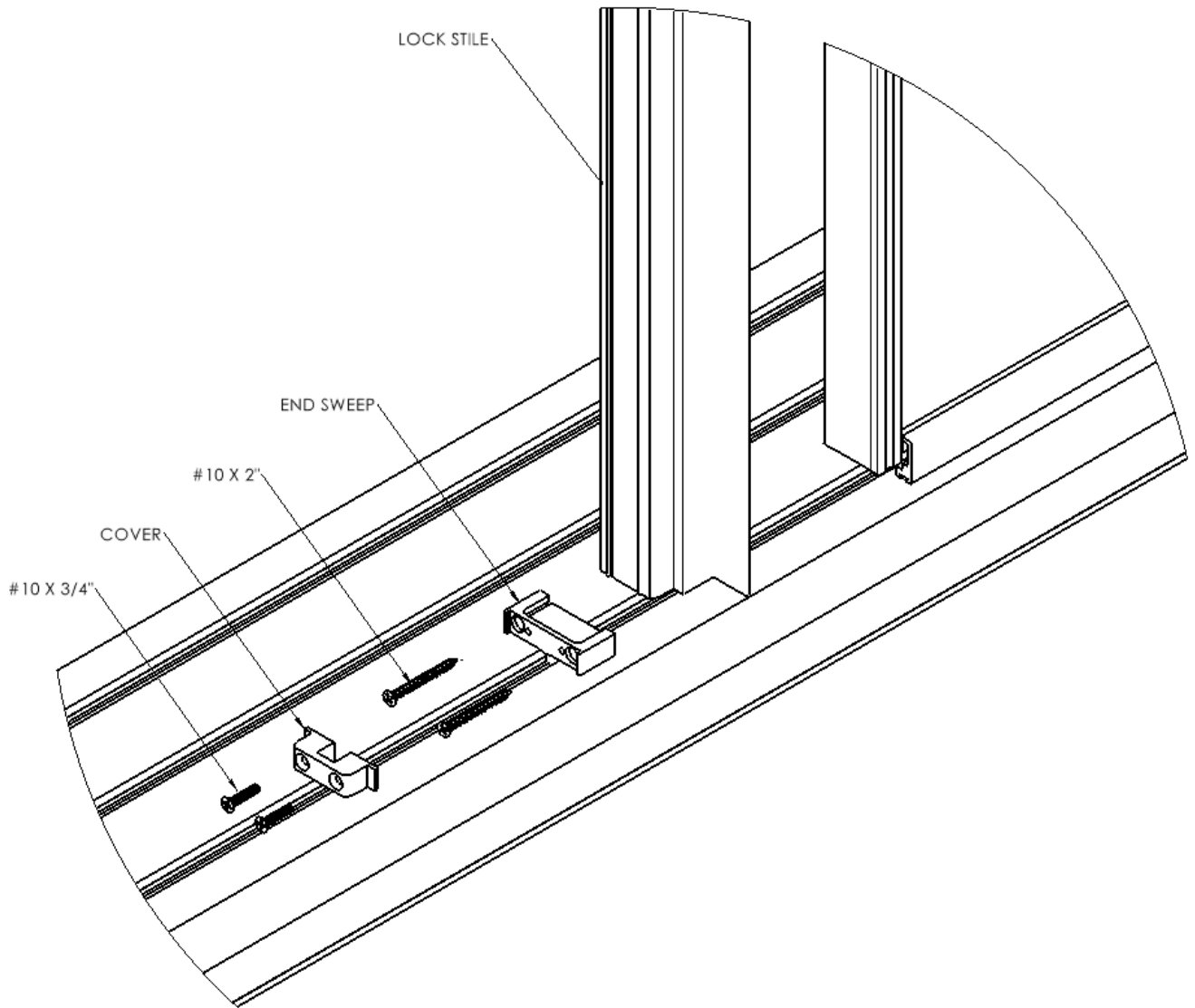

Figure 15 and 16

Identify the intermediate panel that is to be installed in front of the lead panel. Snapping the fin onto the bottom of the panel.

3. Slide the lead panel to the middle of where the adjacent intermediate panel is to be installed. From the exterior of the building and with sufficient overlap of the corresponding interlock, lean the top of the panel into the corresponding head track and lower the fin straight down into the sill assembly.
4. Snap the interlockers onto the intermediate panel and secure them to the panel with the end sweeps and (2) #10 screws.
5. If the door system has fixed panels, they will be installed last.
 - Position the adjacent intermediate panel to allow for the fixed panel interlock to overlap.

- Snap the fin onto the bottom and the panel.
- Ensure that the fixed panel is a few inches away from the jamb with the interlocks overlapping each other.
- Lean the top of the panel into the corresponding head track and lower the panel straight down onto the sill assembly.
- With one hand up top of the fixed interlocker and the ball of foot on the bottom, gently push the fixed panel into the jamb pocket until the bottom rail contacts the jamb face.
- The fixed panels will rest on fixed panel blocks to position it at the correct height over the sill. If the sill is continuous (not staggered), then the fixed panel block located at the interlocker must be used to “anchor” the fixed panel at the sill. The block should be pushed under the fin until screw head on the top block locks the fin in location preventing the panel from pulling out of the jamb. Anchor the block in location with 1) #10 x ¾” screw. See **Figure 16**.

Anchor the head of the fixed panel in location using the anchor clip and (4) #10 x 2” screws. See **Figure 17**.

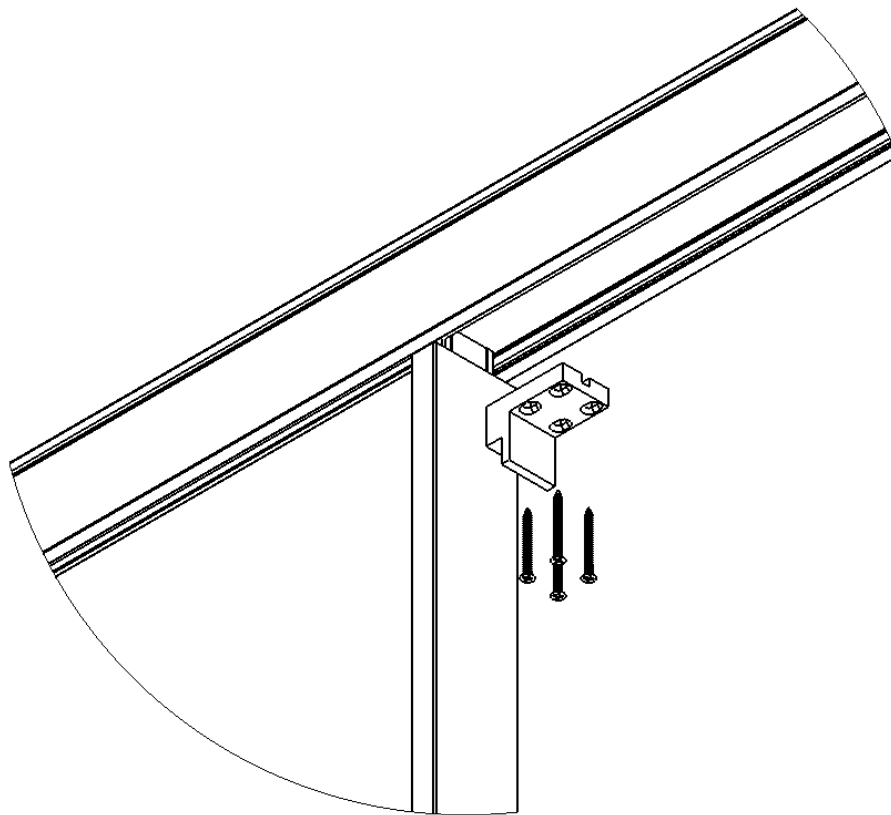

Figure 17

6. Install Jamb and Head fillers. Use caution while snapping fillers into location to prevent denting the fillers.
7. Make all final adjustments to achieve the optimum alignment throughout the door system.
8. Identify and install the lock strike plate to the lock jamb. Move the lead panel close to the jamb and mark the engagement and disengagement of the lock handle on the jamb. Place the lock strike plate onto the jamb and mark the screw hole locations.
9. Drill four (4) 3/16" clearance holes at the marked locations of the strike plate. Anchor the lock strike to the jamb with #10 x 2" PH Flat Head screws into the structure below. Shim as needed to avoid bowing the frame. See **Figure 18**.

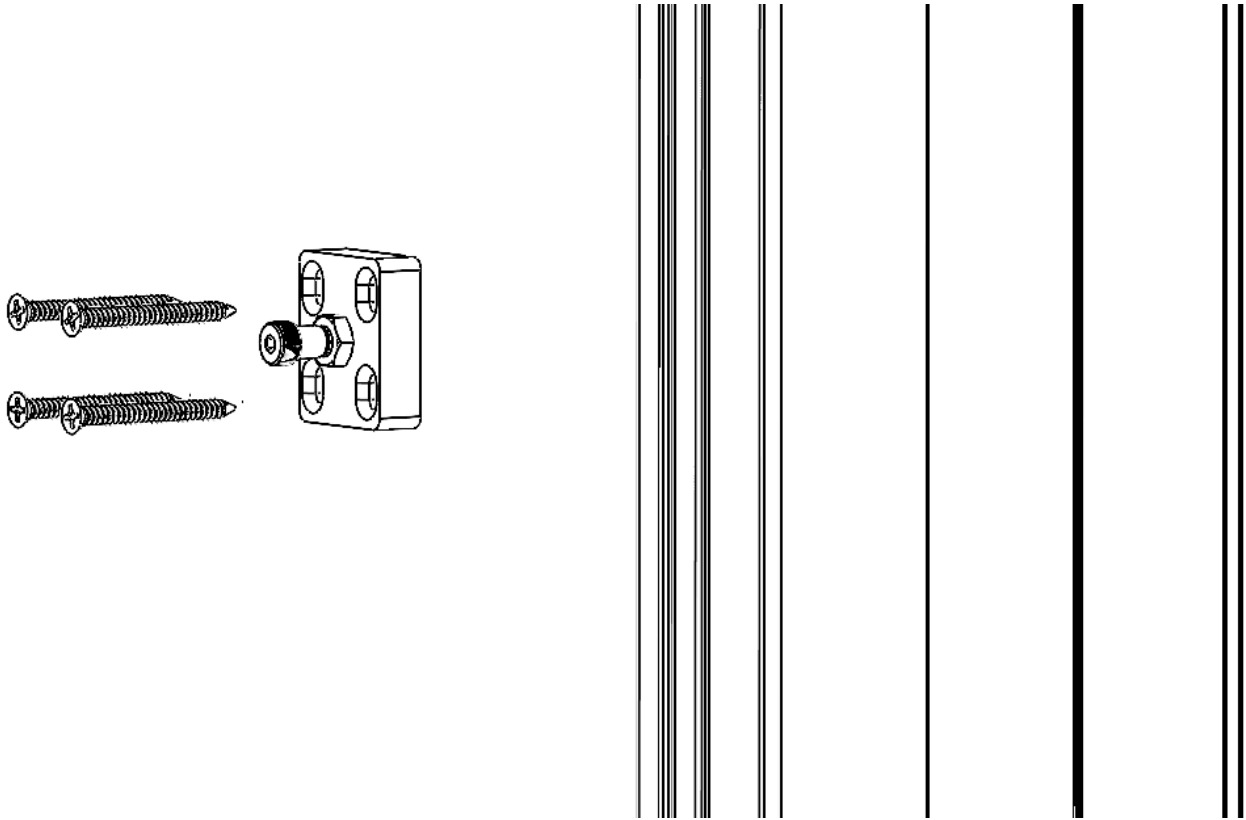

Figure 18

10. Close and lock the active panel to verify engagement and disengagement. Adjust as needed.

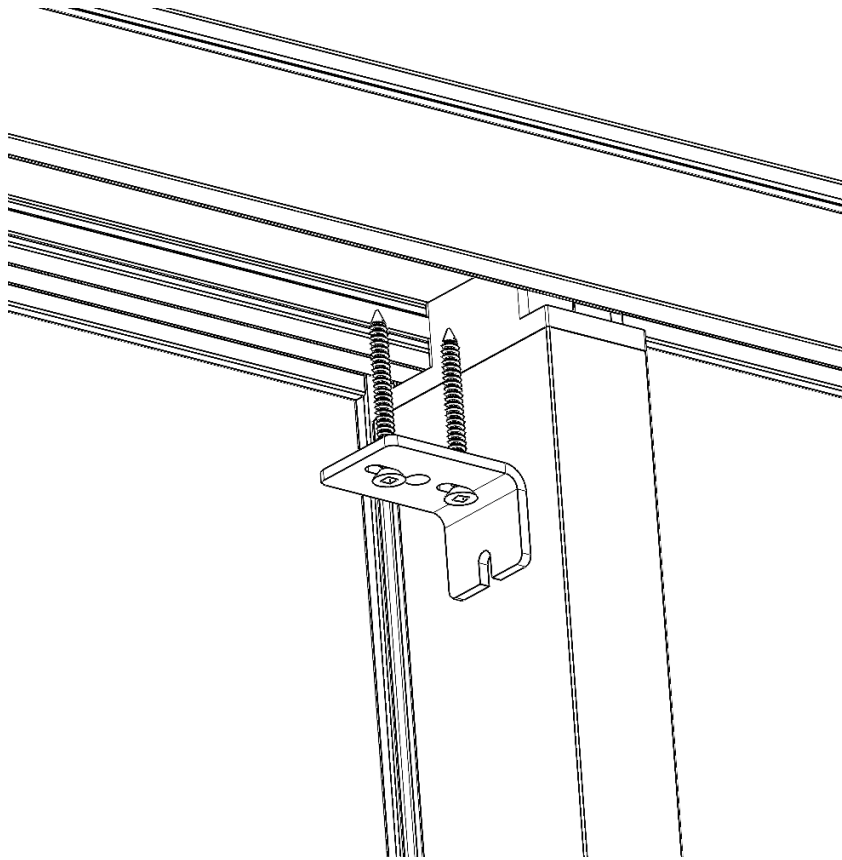

Figure 19 With panels in final positions, locate and install the corresponding head fillers into their respective head tracks.

11. From the interior, seal the fixed panel to the frame sill, jamb, and head. Seal the frame sill to the floor full length.
12. The door installation is complete.