

---

# **KEYED LOCK**

## **INSTALLATION INSTRUCTIONS**





# KEYED LOCK INSTALLATION

---

## STEP 1:

---

Assemble handle. Insert the flat plate into the handle, lock in place using the ¼-20 set screws. The handle should be assembled so that the vertical locking screw is facing the bottom and the horizontal locking screw is covered by the finger pull on lead stile after assembly.

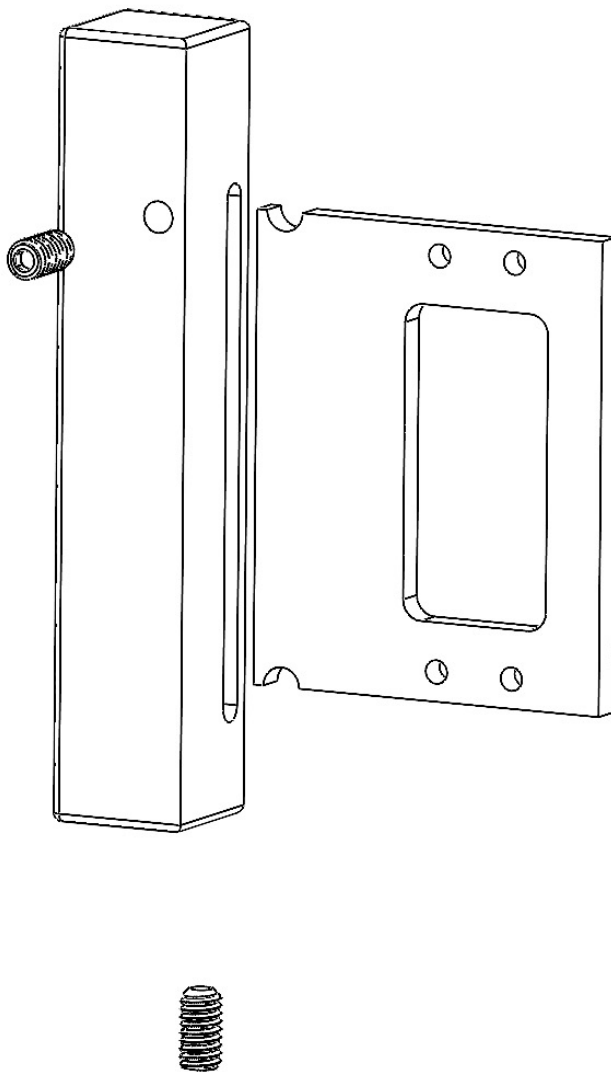

**STEP 2:**

Slide handle into slot cut into the side of the lead stile, check to make sure that the handle assembly orientation is correct.

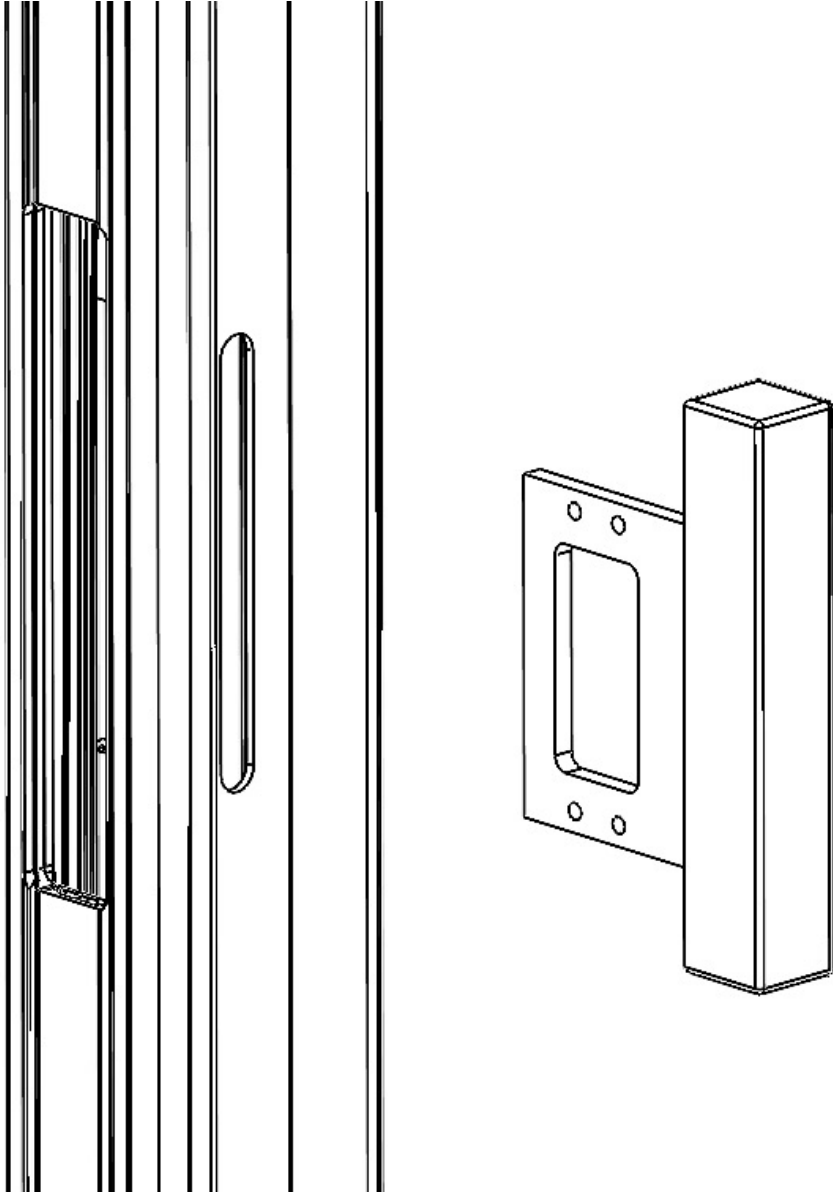

**STEP 3:**

Attach lock block onto handle plate using four (4) of the #10-24 x3/4" length machine screws.

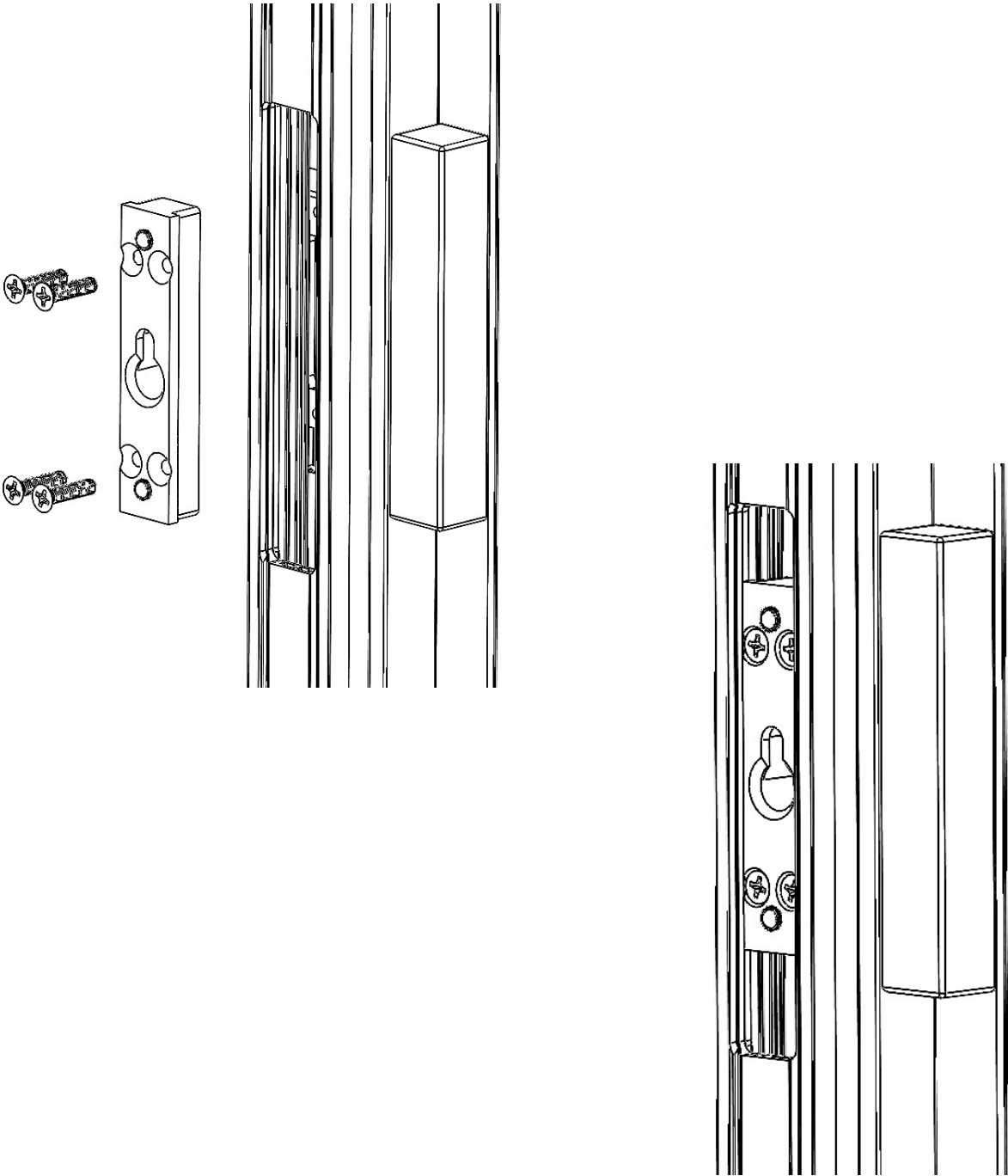

## STEP 4:

Install cover plate using two (2) of the black finished #10-24 x 3/4" machine screws. Lock is installed: check to make sure the handle slides up and down smoothly. Ensure that the handle is "snapping" into the top and bottom locations and is staying in each location.

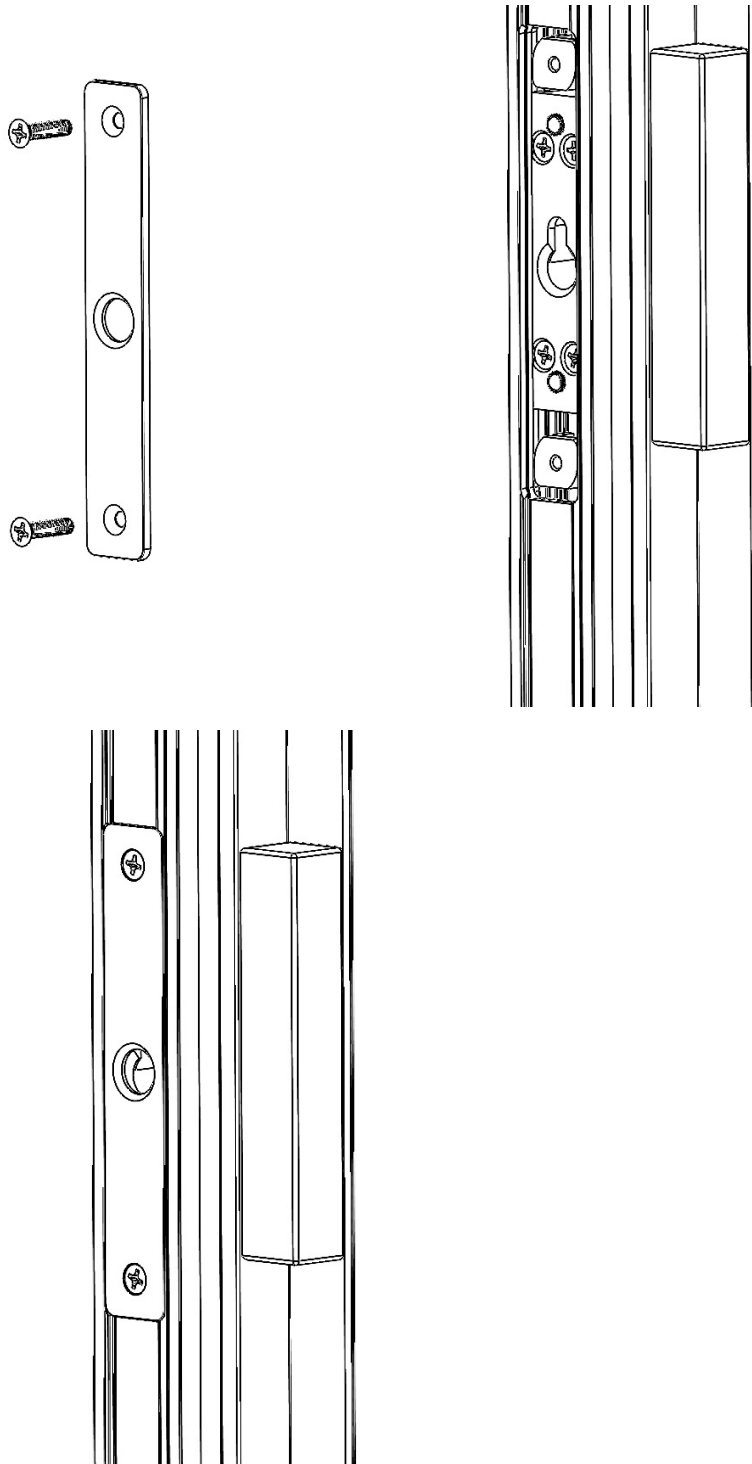



# GET IN TOUCH

**435 E GERMANN RD SUITE 104  
GILBERT, AZ 85297**

[www.awakewdc.com](http://www.awakewdc.com)

(833) 292-5393