

DEDICATED MULLING GUIDE

---

# MULTI-SERIES

INSTALLATION INSTRUCTIONS





## STORAGE AND HANDLING

---

Upon delivery of your Awake Window and Door Company products, confirm that there is no damage that will affect the appearance or performance of the installed product. Inspect the product and hardware components to become familiar with them. Damaged and/or missing parts should be reported to your supplier immediately.

The products must be protected before, during and after installation to prevent damage to the frame finish, hardware and or glass. Awake Window and Door Company manufactured products are to be kept in manufacturers packaging and stored in a dry location protected from the elements until ready for installation. If packaging becomes wet, remove, and immediately replace with dry packaging or covering if possible.

When handling window products, all items should be transported and stored vertically on a flat even surface. Finished product shall not be dragged off any delivery truck or dropped on the floor during storage. Products should only be lifted/moved with glass cups attached directly to the glass and should not be lifted or dragged by the frame, which can damage the product.

For individual product installation instructions, please refer to Awake's website <https://awakewdc.com/install-instructions>.





## PREPARATION

---

Always dispose or recycle any removed window materials properly. For more information, check with your local recycling agency, the U.S. Environmental Protection Agency ("EPA"), or Build Reuse to locate a nearby company or organization that accepts used windows and doors.

**CAUTION: Many homes built before 1978 may have been painted with lead-based paint. Removal of old windows may disturb this paint. Proper precautions must be taken to minimize exposure to dust and debris. Consult state or local authorities and/or the EPA for more information.**

Verify that the number of windows ordered have been received and are manufactured to the specified size and configuration. Inspect and verify the rough opening for the product which you are installing is plumb, level, and approximately 1/2" bigger in width and height than the net frame size.

If your installation includes use of T-bars to form larger units or assembly of units that are shipped knocked down (as unassembled component parts), see T-bar Frame and Knock Down Frame Assembly Instructions below.

If your installation requires that units be mulled together, see Mull Installation Instructions below.

### You May Need to Supply:

---

- Moisture resistant shims/spacers
- Flashing membrane and compatible sealant
- Fasteners
- #10 x 2" PH Flat Head screws (install application)
- Closed cell foam backer rod/sealant backer

### Tools Required for Installation:

---

- Tape Measure
- Pry bar
- Levels of assorted sizes
- 5 in 1 Putty knife
- Laser level (if needed)
- Dead-blow rubber mallet
- Utility Knife
- Quick Clamps
- Sealant Gun
- Suction Glass Cups
- Screw gun with
- #2 Phillips Driver bit
- Drill with
- 3/16", #7, 1/4" drill bit
- #10 Countersink bit.
- #10 x 3/4" screws (Stainless Steel)
- #10 x 2" flat head screws
- #10 x 1-1/4" screws (Stainless Steel)
- #10 x 5/8" screws (Stainless Steel)
- #10 x 1-1/2" screws (Stainless Steel)
- #10 x 1/2" screws (Stainless Steel)
- #10 x 3/8" screws (Stainless Steel)

**Note: Other construction materials may be required. Read the following instructions carefully and inspect the wall conditions before you begin.**

## **WEATHERPROOFING**

---

Rough openings must be protected with waterproofing in accordance with AAMA 2400 Installation Methods, the flashing and sealant manufacturers' instructions, and local building codes. If the product is to be set onto a cement slab, or adjacent with any masonry, a barrier must be employed to ensure there is no direct contact between the product and any cementbased products.

For individual product weatherproofing installation instructions, please refer to Awake's website <https://awakewdc.com/install-instructions>

## **MULL INSTALLATION**

---

Follow these instructions to install two or more products requiring to be field-mulled.

### **Things To Know Before You Start:**

- Drip caps must be used at the head for all vertical mulled units using a nail-fin.
- Make sure to order your drip caps for all your mulled window units. (These ship loose)
- Mull clips will come shipped loose.
- Prior to mulling ensure all mechanical fasteners are not protruding, if some are still proud carefully file fastener head till flush. This will help ensure a even reveal when mulled correctly.
- Once the mulling process is complete and the structural sealant has cured reversing this process is difficult.

## Nail-fin Mull Application Instructions

1. Apply a 1/4" diameter bead of Dow 795 sealant or equivalent sealant in the mull clip groove and at the sealant groove. (See Figure 3). Fixed window example please see appendix for additional frame types.

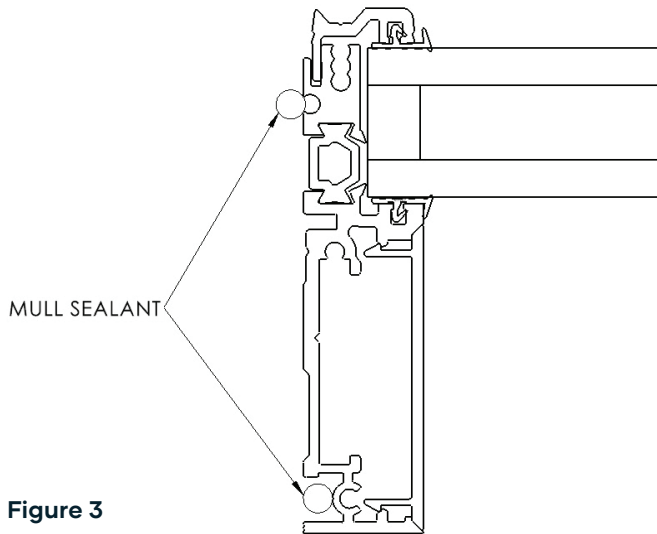

Figure 3

2. Begin to join the two (2) window units together until the frame members come into contact and the mull clip is no longer visible.
3. Verify that the reveal is even from top to bottom. If necessary, use quick clamps with tips protected, and squeeze the units together for an even reveal. See chart below for location and screw sizes for various product types (Figure 5), at 16" on center location, as shown in Figure 4 for units with a horizontal mull greater than 96".

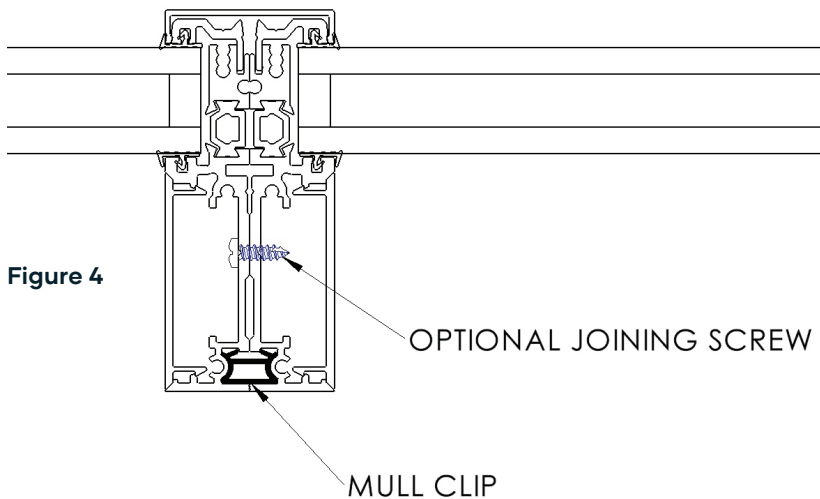
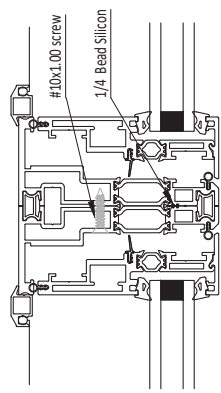

Figure 4

Casement/Awning Muller To Casement/Awning

Figure 5



Fix Muller to Casement/Awning

Figure 5

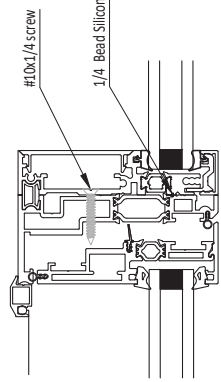

Sliding Glass Door Jamb Muller To Fix

Figure 5

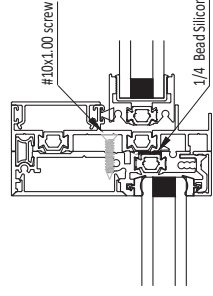

Sliding Glass Door Head Muller To Fix

Figure 5

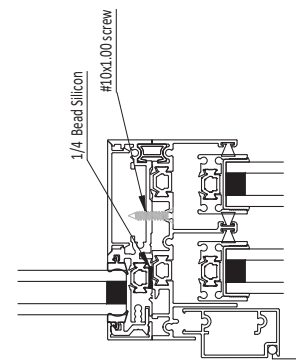

Sliding Glass Door Head Muller To Awning

Figure 5

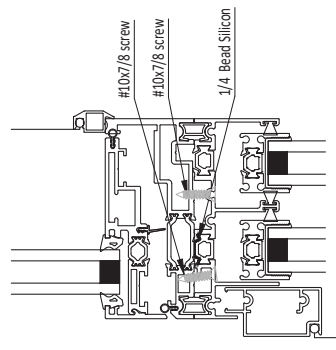

Revision	
----------	--

Customer: Mull Condition

Project:

BY: CAD

DATE:

1

Customer: Mull Condition

BY: CAD

DATE:

2

Hinged Door Head Mull To Fix

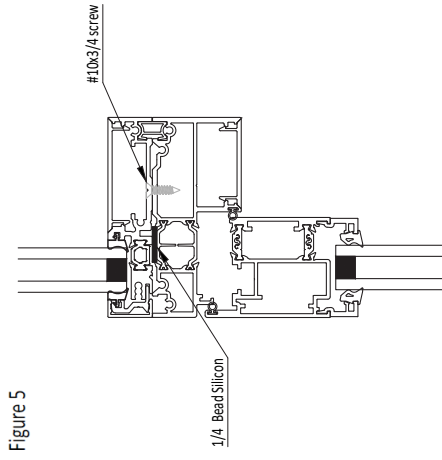

Figure 5

Casement/Awning Mull To Sliding Door Jamb

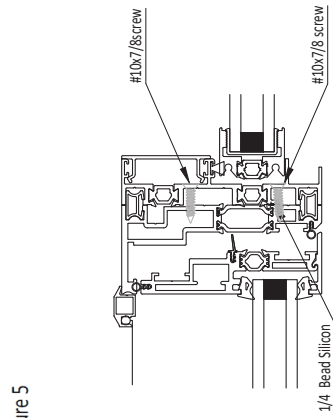

Figure 5

Hinged Door Head Mull To Awning

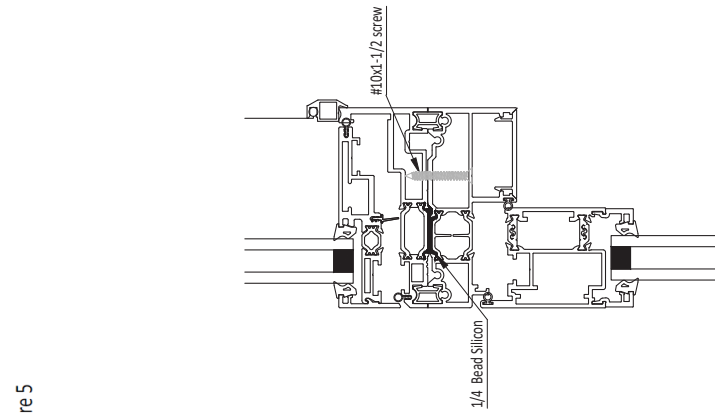

Figure 5

Hinged Door Jamb Mull To Casement/Awning

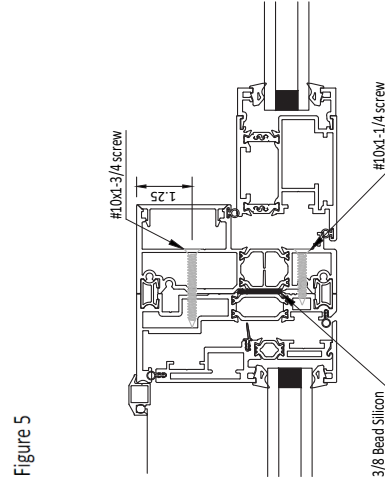

Figure 5

Hinged Door Jamb Mull To Fix

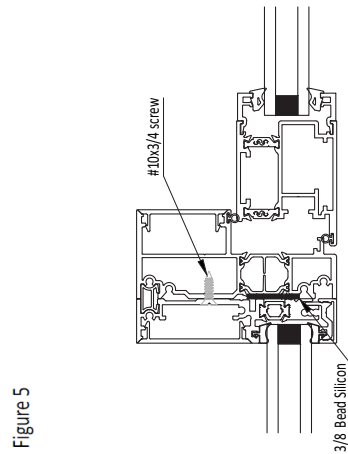
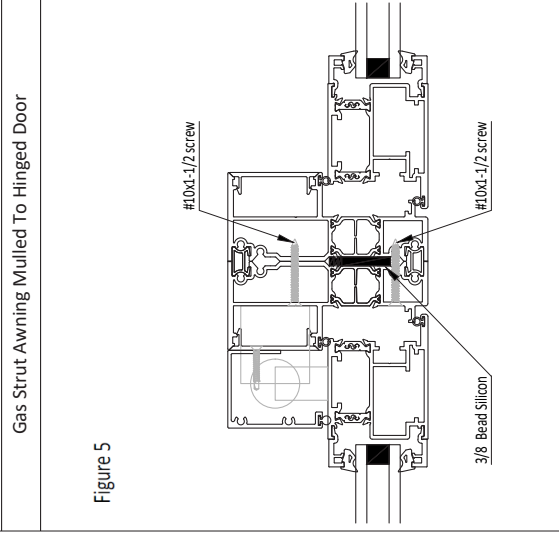
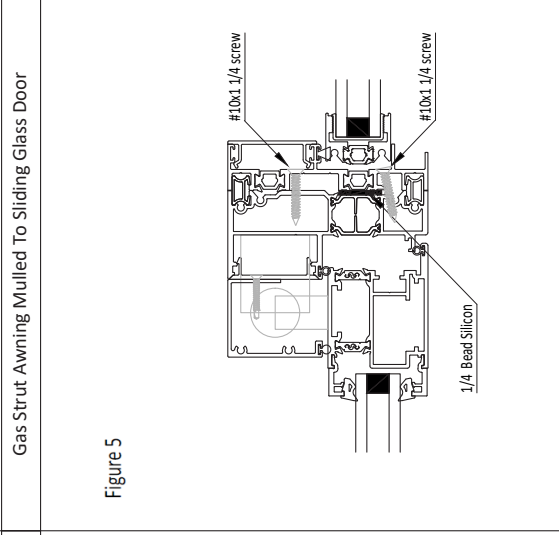
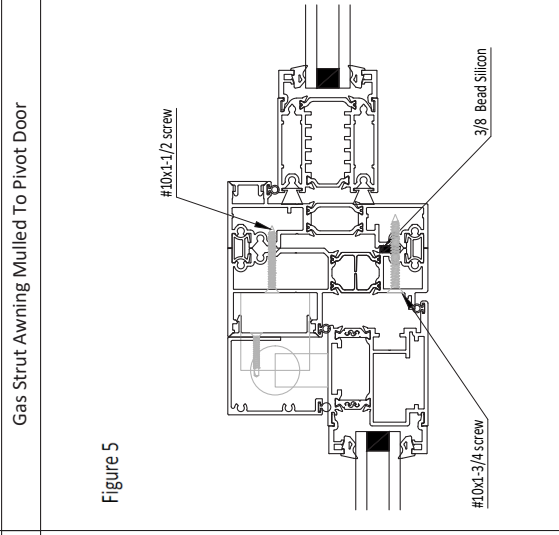
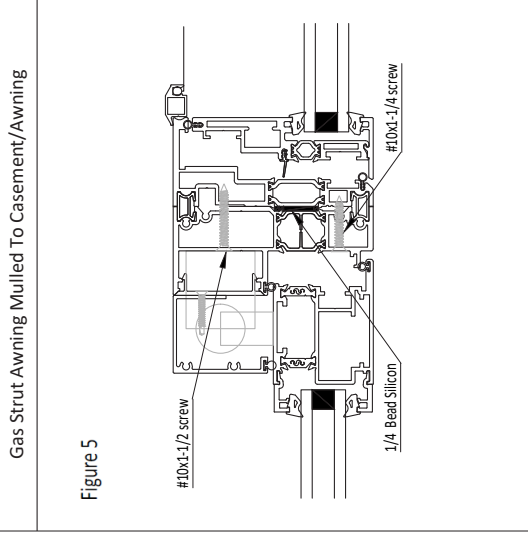
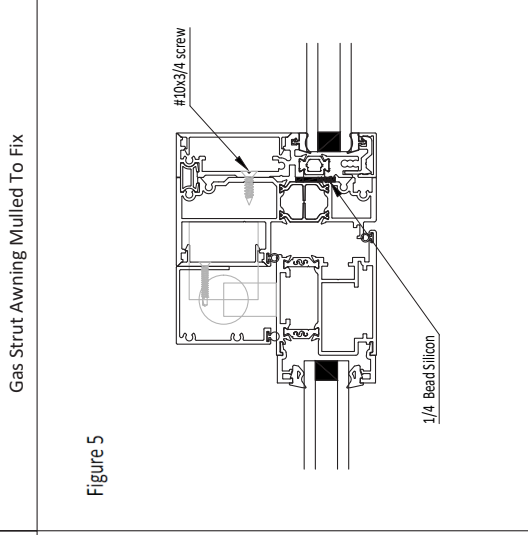
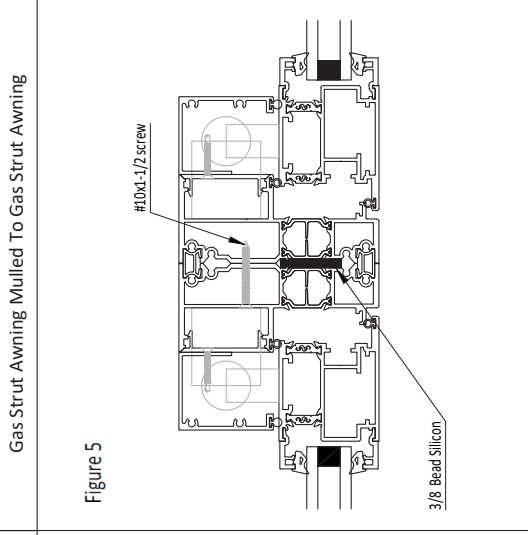

Figure 5



Revision	
Customer:	Mull Condition
Project:	
BY:	CAD
DATE:	
	3





Pivot Door Mullied To Casement/Awning

Figure 5

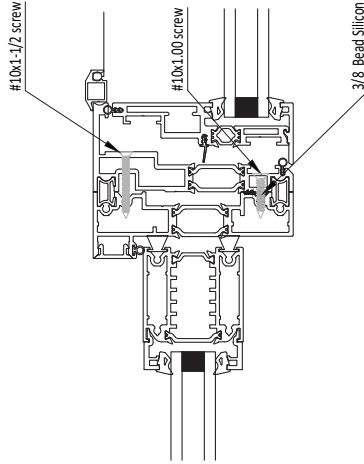

Pivot Door Mullied To Fix

Figure 5

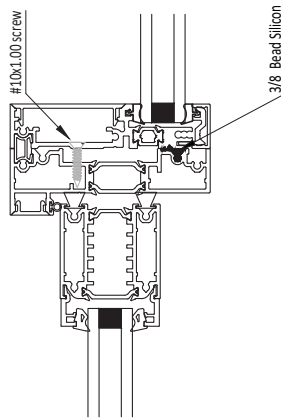

Revision



Project: \_\_\_\_\_  
 Mull Condition \_\_\_\_\_

Customer: \_\_\_\_\_

BY: CAD

DATE:

4



# GET IN TOUCH

**435 E GERMANN RD SUITE 104  
GILBERT, AZ 85297**

[www.awakewdc.com](http://www.awakewdc.com)

(833) 292-5393