

**MULTI-SLIDE  
NON-POCKETING DOOR**

---

**SERIES 905**

---

**INSTALLATION INSTRUCTIONS**



**awake**  
WINDOW & DOOR CO.

## **905 SERIES NAME**

---

Foster care often feeds the prison pipeline.

Our Multi-Slide Door products are named the 905 Series to draw attention to the fact that 90% of foster kids that have 5 or more home placements in their lifetime will end up in the justice system. Our prison system is often full of young people that had extremely difficult upbringings, and prison is rarely the method or place to rectify this. Awake partners with organizations and actively looks to employ at-risk young men and women aging out of the foster care system to help them build a career and avoid the prison cycle. By simply using a 905 series multi-slide you are a part of the solution.

## **NON-POCKETING STACKING SYSTEM**

---

Series 905 Non-pocketing, multi-slide doors are custom manufactured per ordered specifications. It is important that you carefully review and understand the installation instructions and shop drawings contained within these instructions. Disregard or failure to follow these written instructions may result in poor performance of the stacking system including, but not limited to, improper operation, and security issues and may void Awake Window & Door Company's limited warranties. Window products manufactured by Awake Window & Door Company should only be installed by experienced and qualified installation professionals.

## **STORAGE AND HANDLING**

---

Upon delivery of your Awake Window and Door Company products, confirm that there is no damage that will affect the appearance or performance of the installed product. The components required and supplied within the hardware box kits will vary depending on the configuration you are installing. Inspect the product and hardware components to become familiar with them.

Damaged and/or missing parts should be reported to your supplier immediately. If screens are included, they will be packaged separately and are to be installed after the product is finished to avoid damaging the screens.

This product must be protected before, during and after installation to prevent damage to the frame finish, hardware and or glass.

Awake Window and Door manufactured products are to be kept in the manufacturers packaging and stored in a dry location protected from the elements until ready for installation. If packaging becomes wet, remove, and immediately replace with dry packaging or covering if possible.

When handling door products, they should be transported and stored vertically on a flat even surface. All door panels are to be transported and stored upside down to avoid damage to the bottom rail weather seals. Finished product shall not be dragged off any delivery truck or dropped on floor during storage.

## PREPARATION

---

Always dispose or recycle any removed door materials properly. For more information, check with your local recycling agency, the U.S. Environmental Protection Agency ("EPA"), or Build Reuse to locate a nearby company or organization that accepts used windows and doors.

**CAUTION: Many homes built before 1978 may have been painted with lead-based paint. Removal of old doors may disturb this paint. Proper precautions must be taken to minimize exposure to dust and debris. Consult state or local authorities and/or the EPA for more information.**

Verify that the number of doors ordered have been received and are manufactured to the specified size and configuration. Inspect and verify the rough opening for the product which you are installing is plumb, level, and approximately 1/2" bigger in width and height than the net frame size.

Measure and inspect flooring for flat and level. If the floor varies more than 1/16" (.062") per 120-inch span or a total of 3/16" (.188") over the span of the opening width, it must be corrected prior to installation of the door. The sill should be supported by shims every 6" minimum. Failure to adequately install sill may result in operational issues and could result in re-installation of the sill.

### **You May Need to Supply:**

---

- Moisture resistant shims/spacers.
- Flashing membrane and compatible sealant.
- Fasteners:
  - 3/16" Tapcon concrete anchor screws. (Sill concrete anchoring)
  - #10 x 2-1/2" Ph Flat Head screws (Block Frame install application)
- Closed cell foam backer rod/sealant backer

### **Tools Required for Installation:**

---

- Tape Measure
- Levels of various sizes
- Laser level (if needed)
- Plumb bob
- Utility Knife
- Sealant Gun
- Screw gun with:
  - #2 Phillips Driver bit
  - #2 Square Drive

- Drill with:
  - 3/16", #21 drill bit
  - #10 Countersink bit.
- Pry bar
- 5 in 1 Putty knife
- Dead-blow rubber mallet
- Suction Glass Cups
- Quick Clamps

**Note: Other construction materials may be required. Read the following instructions carefully and inspect the wall conditions before you begin.**

## Frame Components

---

Perimeter frame shall consist of one (1) head and sill assembly, two (2) jamb assemblies, jamb fillers and hardware box kits.

If the total frame width exceeds 240" (20'-0") the head and sill assemblies will be supplied in two (2) sections to be sealed and joined during installation.

## Panel Components

---

Unless noted may contain the one or more options of the following:

### Standard doors:

- one (1) or two (2) active lead panel (contains lock and handle assembly)
- one (1) or several intermediate panels
- one (1) or several fixed panels
- one (1) or several screen panels

### Bi-parting stacking doors:

- one (1) active lead panel (contains lock and handle assembly)
- one (1) in-active lead panel
- one (1) or several intermediate panels
- one (1) or several fixed panels
- one (1) or several screen panels

If a bi-parting door is requested, you will have one (1) active lead panel and one inactive lead panel. The active panel and will be installed to the left of center, as viewed from the exterior of the building.

# WEATHERPROOFING

Rough openings must be protected with waterproofing in accordance with AAMA 2400 Installation Methods, the flashing and sealant manufacturers' instructions, and local building codes. If the product is to be set onto a cement slab, or adjacent with any masonry, a barrier must be employed to ensure there is no direct contact between the product and any cement-based products.

# FRAME INSTALLATION

1. Refer to the shop drawings supplied and inspect the rough opening carefully to ensure it has been prepared correctly to accept the width, height, and depth of the door you are installing.
2. If the door frame is to be set on a wood substrate, the wood must be protected with an appropriate flashing or waterproofing membrane prior to door frame installation.
3. Measure and inspect flooring for flat and level. If the floor varies more than 1/16" (.062") per 60-inch span or a total of 1/4" (.25") over the span of the opening width, it must be corrected prior to installation of the door.
4. The frame will need to have all installation holes drilled prior to caulking, sealing, and setting of the frame. Pre-drill required installation holes with a 3/16" drill bit as follows:
  - Frame Head – 12" from each end and every 24" on center, per track. (See Figure 1)

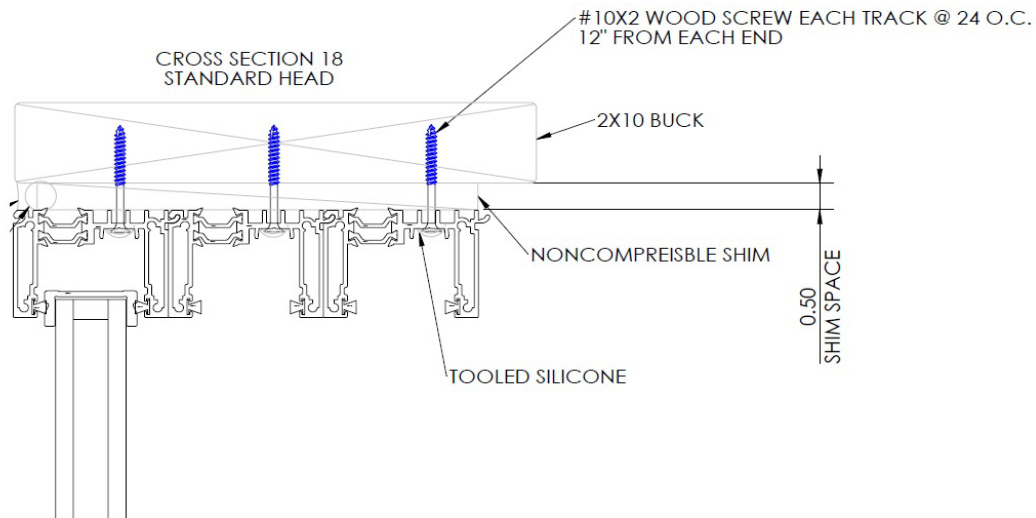

Figure 1

- Sill – 12" from each end and every 24" on center per track. (See Figure 2)

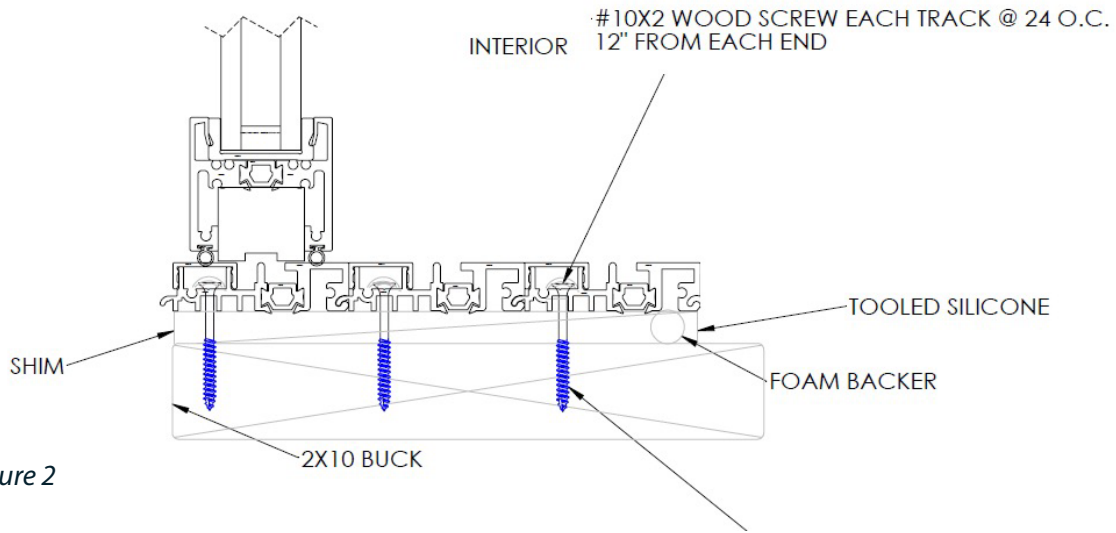

Figure 2

- Jambs – 12" from each end and every 24" on center per track. (See Figure 3)

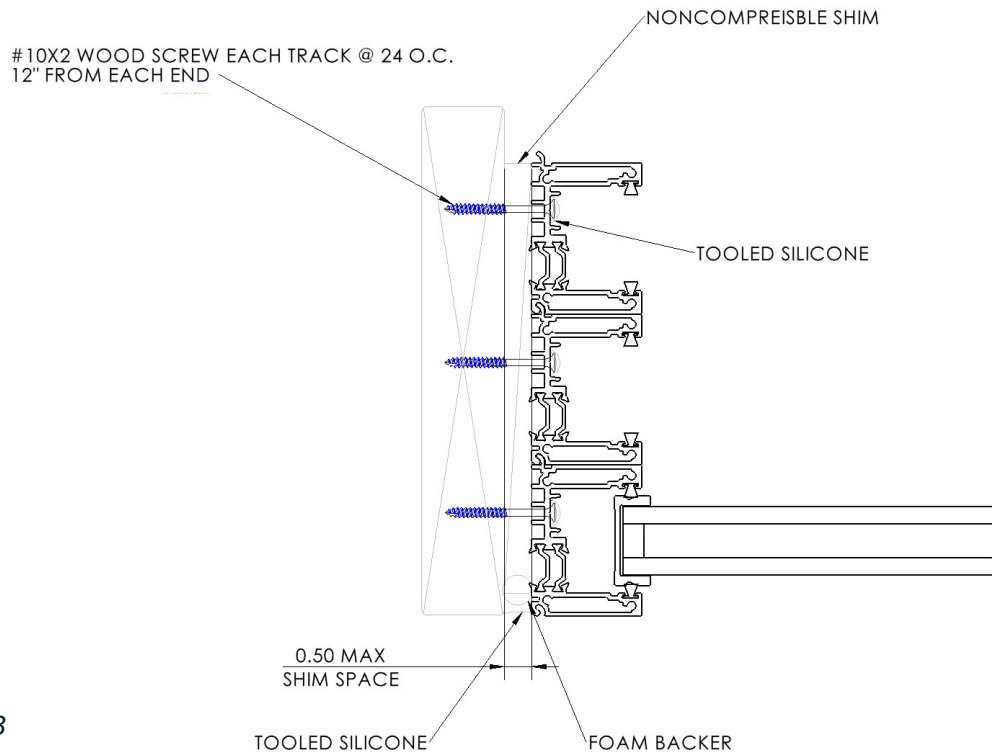

Figure 3

5. Determine the bottom side of the sill by locating the continuous weep channel for drainage of the system. Rotate the sill with weep slots facing down and set the sill on the floor in the approximate location. Ensure that the edge of the frame is aligned with the structure.

6. Inspect the sill where it encounters the surface of the floor. Inspect and mark any gaps that will need to be shimmed, filled or humps removed prior to final installation. The final installation requires the that the sill be level and supported across the full span for proper operation.
7. Once the sill is in the correct location, inspect the header above to confirm that the frame head can be installed directly above the sill at the proper height as required. If no correction is to be made to the frame, mark the inside edge of the frame sill full-length to ensure correct location and positioning when anchoring.
8. Begin to mark the flooring through each hole that was previously drilled to anchor the frame to the rough opening. Start from the exterior left side and mark every hole to the right until complete, remove the sill and prepare the opening.
9. If the door is being set on concrete, use the appropriate drill for minimum 3/16" Tapcon anchor screws.

**Note: If you choose to drill the anchor holes into the concrete while the sill assembly is still in place, you must vacuum the debris from the top of the sill as well as from below to ensure that the caulking and or roller assemblies do not get contaminated. Figure 4**

10. If the floor is wood with a waterproofing membrane or flashing applied, apply a generous amount of appropriate and compatible sealant at each mark where an installation anchor screw will penetrate the waterproofing.
11. With the sill assembly removed, and clean from debris, apply a 1/2" bead of sealant to the floor from jamb to jamb along the exterior edge of the mark previously applied to the floor. The sealant should be applied in a U-shape to ensure a proper and complete water-barrier has been accomplished across the full width of the sill opening, and at least 6" up each side. (See Figure 4)

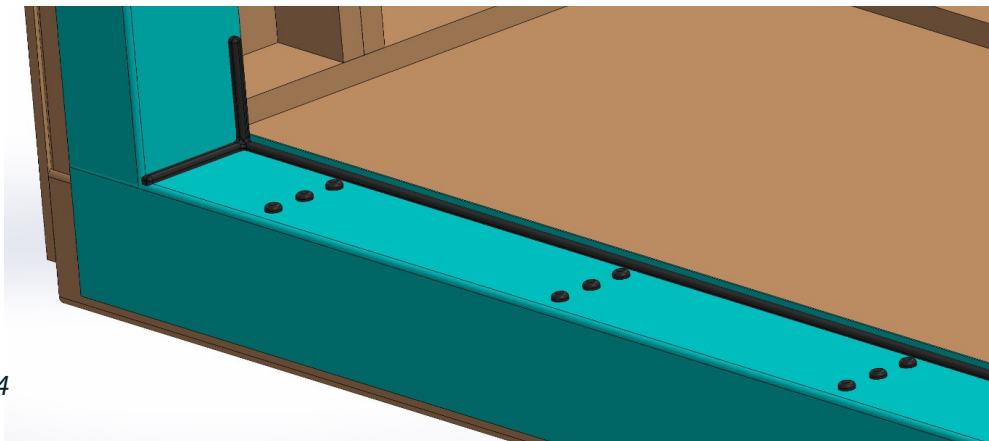

Figure 4

12. Set the sill assembly onto the bed of sealant and align the sill with marks on the floor. Shim the sill assembly as required and secure the frame with adequate anchor screws for your application. Once the sill is anchored to the floor, verify that it is 100% flat and level in all directions. After verification, locate, and apply all snap-in beauty covers to conceal the anchor screws and create a flat surface for the panels to seal against. (See Figure 5)

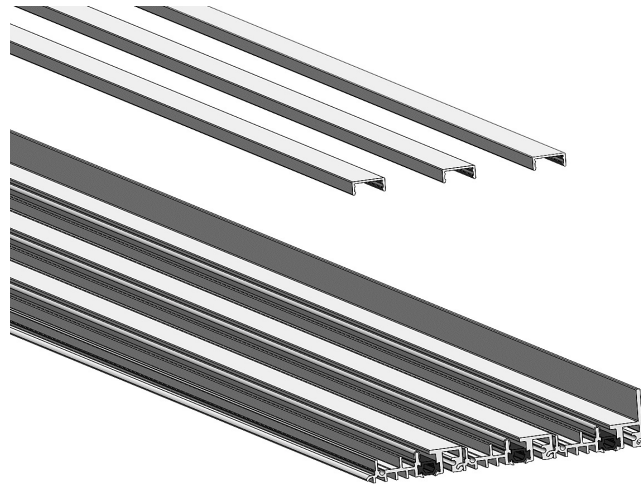

Figure 5

13. Measure and inspect the header of the rough opening to ensure that the frame head and jamb assemblies will fit with sufficient backing for anchoring. Based on your net frame size as indicated by your drawings or purchase order, ensure whether additional material is needed to be added to the header prior to installation to minimize excessive shimming.
14. Using a plumb bob or laser level, mark several points onto the header framing to locate and position the head assembly parallel to the sill assembly. With assistance, carefully raise the head assembly onto the framing header and secure temporarily with #10 x 2" PH Flat head screws as needed to hold the head assembly safely in place.
15. Locate and set each jamb between the sill and the head assembly. Set the jamb in place and ensure it is in-line with the head. Ensure the sill is plumb and level. Raise or lower the head assembly to align with the jamb as needed. Once set in place, secure the jamb to the rough opening temporarily with #10 x 2" PH Flat head screws as needed to hold the jamb safely in place.
16. Pre-drill the jamb to the end plate assembly holes at each end and as required with a #21 drill bit. Remove the jamb assembly and seal the jamb to the end plate interface at the sill location with Dow 795 sealant. (See Figures 6 & 7)

Figure 6

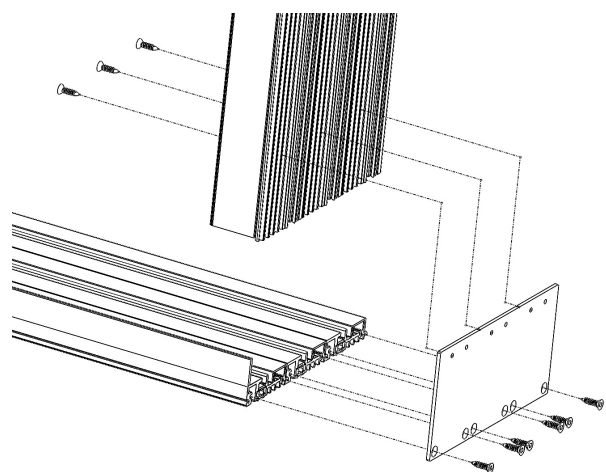
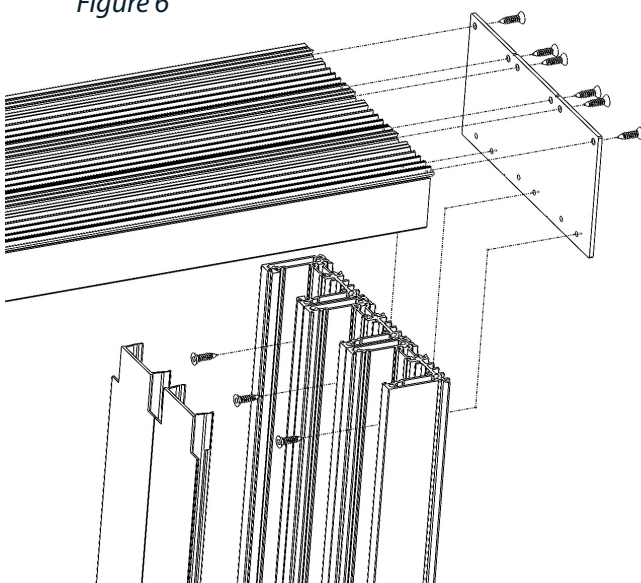

Figure 7



17. Reinstall the jamb assembly and secure to the frame head and sill with #10 x 1" Ph Flat Head screws. Shim as needed and continue to secure the jamb to the rough opening with #10 x 2" PH Flat head screws through remaining holes.
18. Complete the anchoring of the frame head assembly ensuring it is true and parallel with the sill assembly. Identify and apply all snap-in beauty covers to conceal the anchor screws and create a smooth finished surface.
19. Complete the jamb assembly by locating and applying the snap-in beauty cover to the locking jamb which will be visible when the door panel is open. Continue to finish the jamb assembly by lightly tapping the remaining jamb fillers onto the jamb with a non-marring rubber mallet.

## PANEL INSTALLATION

---

1. Locate the active lead panel and insert it into the installed frame.
  - For XO configurations, place lead panel at left of door system.
  - For OX configurations, place lead panel at right of door system.

**Note: If a bi-parting door is requested, you will have one (1) active lead panel and one inactive lead panel. These panels are to be installed on the innermost track. The active panel will be installed to the left of center, as viewed from the exterior of the building. Fixed panels have one (1) interlock, no rollers and rest on the outermost track. Intermediate panels will have two (2) interlock stiles.**

2. From the exterior of the building and the locking handle to the interior of the building, lean the top of the panel into the innermost head track and lower the panel straight down onto the sill assembly.
3. Identify the install kit boxes containing the roller assemblies, roller shim stacks and end sweeps needed for the panel installed and the remaining panels.

**Note: The kits will include all necessary roller assemblies and respective hardware for your panels, which will vary depending on the size of the door system.**

4. The number of roller assemblies divided by the number of operable panels will determine how many rollers will be needed for each panel.

**Example:** A 4' wide panel may take four (4) roller assemblies; two (2) per side. A 5' wide panel may take six (6) roller assemblies; (3) per side and so on. The number of roller assemblies supplied varies with each door system depending on configuration and specifications selected.

5. Determine the number of roller assemblies needed per panel and connect by sliding one (1) roller assembly onto the other. Continue this process for all required rollers. Once complete, slide the end sweep onto the roller assembly and set roller assemblies in front of panel.

6. Taking care not to scratch or shift the lead panel over. With a pry bar, lift the panel high enough to slide the roller assembly system into place. Ensure that all rollers rest onto the track cap and roll freely. (See Figure 8)

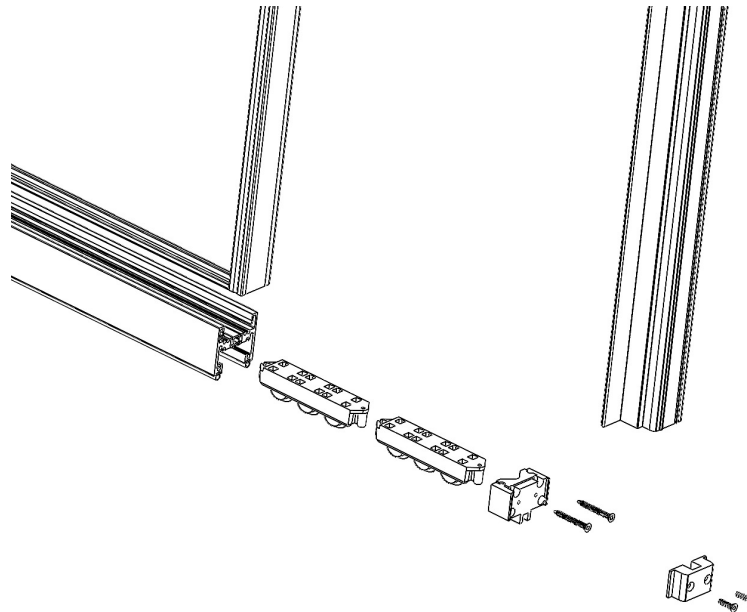

Figure 8

7. If needed and for adjustment, the roller assembly can be shimmed individually or per side with supplied shim stacks. Each shim is .015" thick and up to three (3) roller shims per roller assembly can be used. Once the roller assembly is set into the panel, continue with the opposite side.
8. With the weight of the panel on the rollers, slide the panel to the lock jamb and ensure that the vertical gap is consistent from top to bottom and no additional shimming is needed. Fasten the end sweep onto the stile with a #8 x 1" PH Flat head screw.
9. Identify the intermediate panel that is to be installed in front of the lead panel. Slide the lead panel to the middle of where the adjacent intermediate panel is to be installed. From the exterior of the building and with sufficient overlap of the corresponding interlock, lean the top of the panel into the corresponding head track and lower the panel straight down onto the sill assembly.
10. Identify the roller assembly and connect by sliding one (1) roller assembly onto the other. Repeat this step for all required rollers. Once all rollers are installed, slide the end sweep onto the roller assembly and set roller assemblies in front of panel.

11. Taking care not to scratch or shift the lead panel over. With a pry bar, lift the panel high enough to slide the roller assembly into place. Ensure that all rollers rest onto the track cap and roll freely. (See Figure 9)

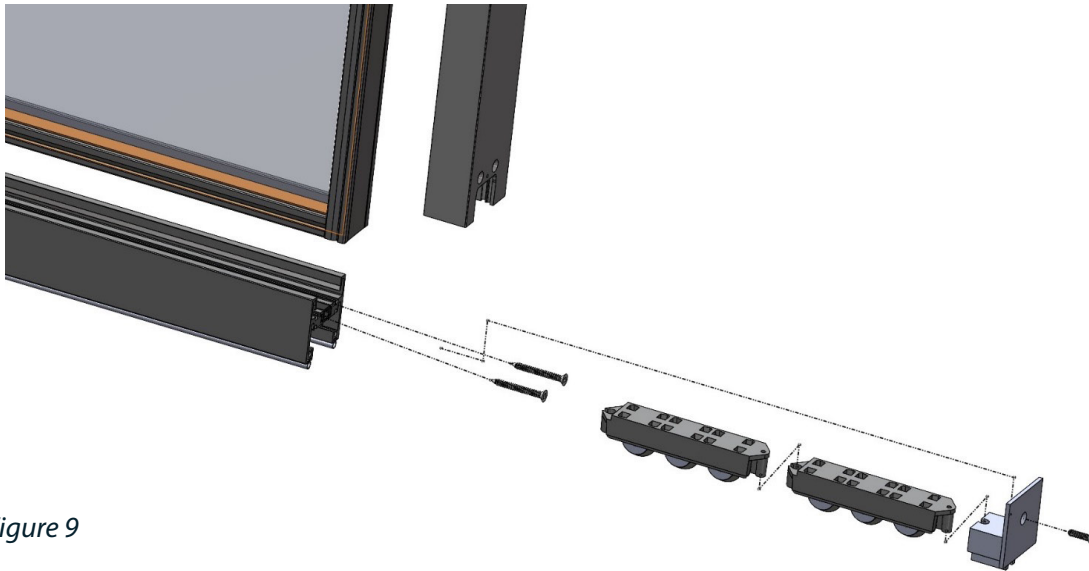

Figure 9

12. With the weight of the panel on the rollers, slide the panel back and forth and ensure that the vertical gap is consistent from top to bottom and no additional shimming is needed. Fasten the end sweep onto the stile with a #8 x 1" PH Flat head screw.
13. If the door system has fixed panels, they will be installed last. Position the adjacent intermediate panel to allow for the fixed panel interlock to overlap. Ensure that the fixed panel is a few inches away from the jamb with the interlocks overlapping each other. Lean the top of the panel into the corresponding head track and lower the panel straight down onto the sill assembly.
14. With one hand up top of the fixed interlock and the ball of foot on the bottom, gently push the fixed panel into the jamb pocket until the bottom rail contacts the jamb face. Make all final adjustments to achieve the optimum alignment through the door system.
15. Identify and install the lock strike plate to the lock jamb. Move the lead panel close to the jamb and mark the engagement and disengagement of the lock handle on the jamb. Place the lock strike plate onto the jamb and mark the screw hole locations.

16. Drill four (4) 3/16" clearance holes at the marked locations of the strike plate. Anchor the lock strike to the jamb with #10 x 2" PH Flat Head screws. Shim as needed to avoid bowing the frame. (See Figure 10)

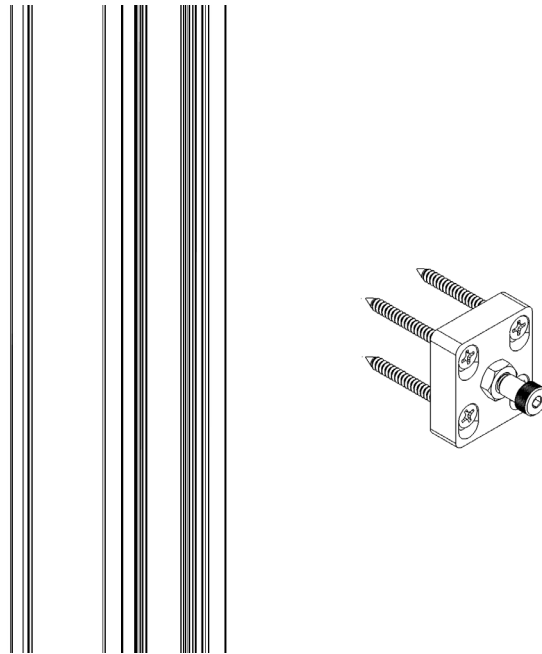

Figure 10

17. Close and lock the active panel to verify engagement and disengagement. Adjust as needed.
18. The meeting interlock should line up from top to bottom and fully engage. Ensure frame and panels are plumb and square and that the fixed panel is fully seated in the jamb channel. Adjust as needed.
19. With the frame head parallel with the sill assembly, secure the fixed panel. Position the fixed clip into the head, using the clip pre-drilled holes as a guide, drill clearance holes for assembly screws. Anchor the fixed clip to the frame head with a pair of #10 x 2" PH Flat Head screws. (See Figure 11)

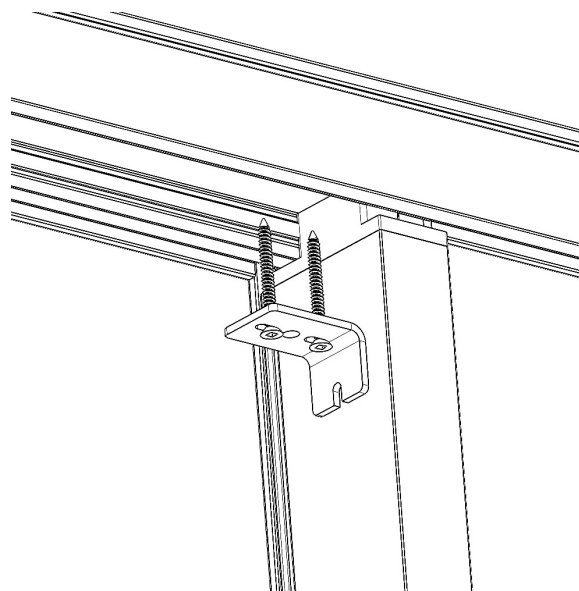

Figure 11

20. With panels in final positions, locate and install the corresponding head fillers into their respective head tracks.
21. From the interior, seal the fixed panel to the frame sill, jamb, and head. Seal the frame sill to the floor full length.
22. The door installation is complete.

### **TESTING**

**No field testing or studies are permitted on Awake's products unless they are performed in strict compliance with the Fenestration and Glazing Industry Alliance (FGIA) Voluntary Specification for Field Testing of Newly Installed Fenestration Products, AAMA 502 and strictly comply with Awake's Testing Requirements and Conditions, available at [www.awakedc.com/install-instructions](http://www.awakedc.com/install-instructions)). Failure to strict comply with the foregoing testing requirements will void Awake's 10-Year Limited Warranty.**



# GET IN TOUCH

**435 E GERMANN RD SUITE 104  
GILBERT, AZ 85297**

[www.awakewdc.com](http://www.awakewdc.com)

(833) 292-5393