

WINDOW WALL

---

**SERIES 425**

---

INSTALLATION INSTRUCTIONS



**awake**

WINDOW & DOOR CO.

## **425 SERIES NAME**

---

The USA locks up more people than any other country.

Our Window Wall products are named the 425 Series to draw attention to the fact that the USA has 4% of the world's total population but has 25% of the world's total prison population. We are locking up more people and for longer duration than countries like Russia or China, and it's not even close. This not only hurts those who are incarcerated, it also costs taxpayers over \$182 billion a year. Let's work together to help combat mass incarceration in the United States of America. A great place to start is creating good jobs for those leaving prison.

## **WINDOW WALL**

---

Series 425 Fixed Window Walls are custom manufactured specific to each order specifications. It is important that you carefully review and understand the installation instructions and any drawings supplied for your project prior to installation of any products. Disregard or failure to follow these written instructions may result in deficient performance of your newly installed product including, but not limited to water intrusion, improper operation, and security issues and may void Awake Window & Door Company's limited warranties. Window products manufactured by Awake Window & Door Company should only be installed by experienced and qualified installation professionals.

## **STORAGE AND HANDLING**

---

Upon delivery of your Awake Window and Door Company products, confirm that there is no damage that will affect the appearance or performance of the installed product. Inspect the product and hardware components to become familiar with them. Damaged and/or missing parts should be reported to your supplier immediately.

The products must be protected before, during and after installation to prevent damage to the frame finish, hardware and or glass. Awake Window and Door Company manufactured products are to be kept in manufacturers packaging and stored in a dry location protected from the elements until ready for installation. If packaging becomes wet, remove, and immediately replace with dry packaging or covering if possible.

When handling window products, all items should be transported and stored vertically on a flat even surface. Finished product shall not be dragged off any delivery truck or dropped on the floor during storage. Products should only be lifted/moved with glass cups attached directly to the glass and should not be lifted or dragged by the frame, which can damage the product.

# PREPARATION

---

Always dispose or recycle any removed window materials properly. For more information, check with your local recycling agency, the U.S. Environmental Protection Agency ("EPA"), or Build Reuse to locate a nearby company or organization that accepts used windows and doors.

**CAUTION: Many homes built before 1978 may have been painted with lead-based paint. Removal of old windows may disturb this paint. Proper precautions must be taken to minimize exposure to dust and debris. Consult state or local authorities and/or the EPA for more information.**

Verify that the number of windows ordered have been received and are manufactured to the specified size and configuration. Inspect and verify the rough opening for the product which you are installing is plumb, level, and approximately 1/2" bigger in width and height than the net frame size.

If your installation includes use of T-bars to form larger units or assembly of units that are shipped knocked down (as unassembled component parts), see **T-bar Frame and Knock Down Frame Assembly Instructions** below.

If your installation requires that units be mulled together, see **Mull Installation Instructions** below.

## **You May Need to Supply:**

---

- Moisture resistant shims/spacers
- Flashing membrane and compatible sealant
- Fasteners
- #10 x 2" PH Flat Head screws (install application)
- Closed cell foam backer rod/sealant backer

## **Tools Required for Installation:**

---

- Tape Measure
- Pry bar
- Levels of assorted sizes
- 5 in 1 Putty knife
- Laser level (if needed)
- Dead-blow rubber mallet
- Utility Knife
- Quick Clamps
- Sealant Gun
- Suction Glass Cups
- Screw gun with
  - #2 Phillips Driver bit
  - #2 Square Drive
- Drill with
  - 3/16", #7, 1/4" drill bit
  - #10 Countersink bit.
- #10 x 3/4" screws (T-bar install only)
- #10 x 2" flat head screws
- #10 x 1-1/4" screws (T-bar install only)
- #10 x 5/8" screws (T-bar install only)
- #10 x 1-1/2" screws (T-bar install only)

**Note: Other construction materials may be required. Read the following instructions carefully and inspect the wall conditions before you begin.**

## WEATHERPROOFING

Rough openings must be protected with waterproofing in accordance with AAMA 2400 Installation Methods, the flashing and sealant manufacturers' instructions, and local building codes. If the product is to be set onto a cement slab, or adjacent with any masonry, a barrier must be employed to ensure there is no direct contact between the product and any cement-based products.

## NAIL FIN INSTALLATION

1. Apply a 1/2" continuous bead of sealant to the interior face of both sides and the top of the nail-fin perimeter.
2. Set window into the flashed opening ensuring that the nail-fin makes full contact with the opening.
3. Check that the unit is plum, level and square in the opening and shim as needed.
4. Anchor the window nail-fin to the structure through the nail fin with #10 x 2" screws every 12" on center and 4" from each corner. (See Figure 1).

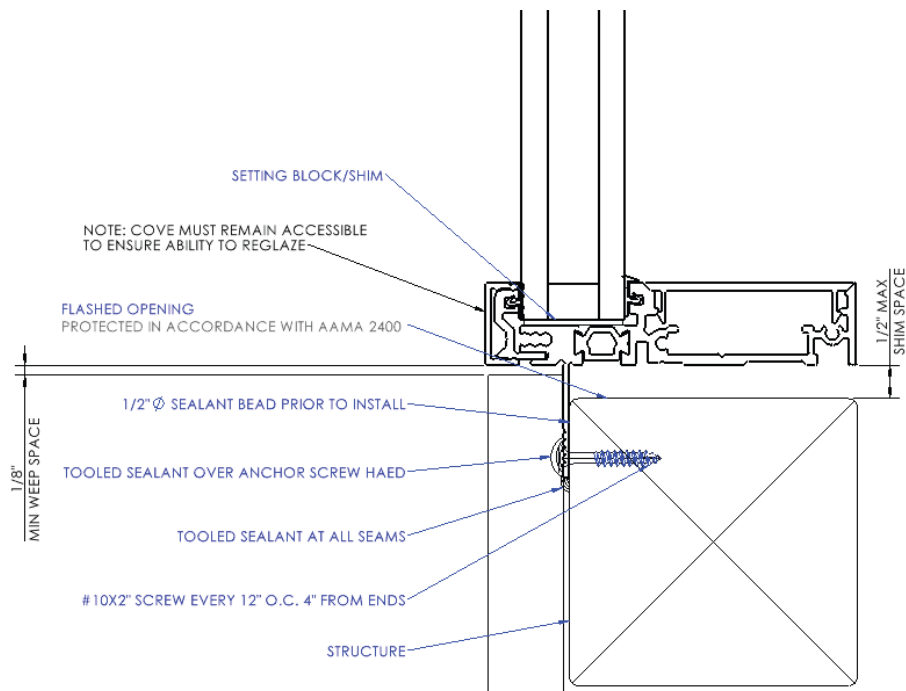

Figure

5. Inspect the frame to ensure it is plumb, level and square. Ensure the window is not racked or crooked within the opening.
6. Ensure that all nail-fin butt joints are sealed as well as the head of every screw that penetrated the nail-fin. Apply approved flashing membrane in accordance with sheathing or house wrap manufacturer's specifications. First, apply the membrane to both sides of the nail-fins. Extend flashing beyond sill flashing and above the top of the nail-fin. Extend top flashing beyond each side flashing by a minimum of 2".
7. Installation is complete.

## **BLOCK FRAME INSTALLATION**

1. If you are installing a standalone unit, proceed with Step 3 of the Block Frame Instructions.
2. If you are installing a mullied unit, proceed to mulling instructions below.
3. Approximately 1-1/2" to 2" in from the exterior face of the rough opening, apply a 1/2" bead of sealant the full width of the sill opening and 4" up both jambs.

**Note: This step of properly sealing the rough opening is critical to ensure a watertight installation.**

4. With a thin pry bar or thin putty knife, locate the edge of the interior cover to the frame joint and pry the cover off the frame. (See Figure 2).

**Note: take caution with removing the interior covers as damage can occur if care is not taken.**

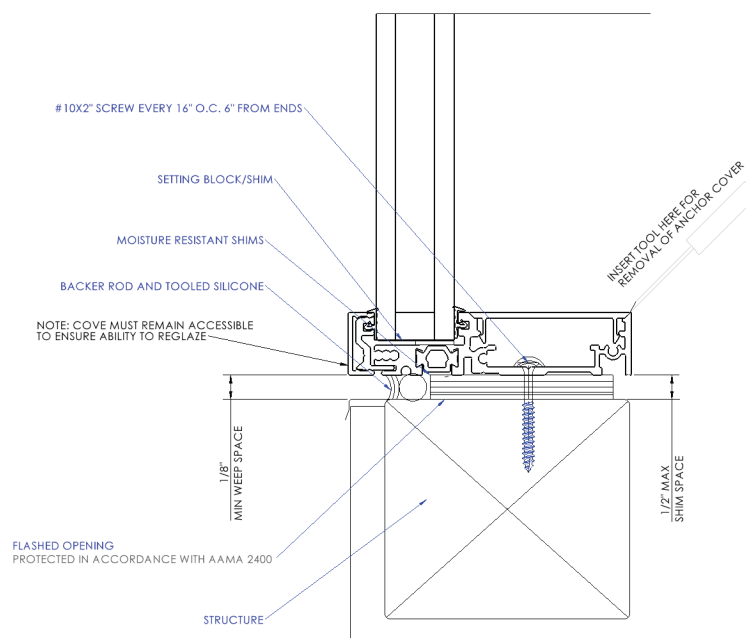

Figure 2

5. Continue removing the remaining cover from the frame exposing the anchoring channel.
6. Using the v-groove on the frame profile, drill 3/16" installation holes 6" from each end and every 16" thereafter.
7. Countersink the installation holes to accommodate a #10 Flat Head screw.
8. Lift unit into the opening and secure in place with shims as needed.
9. Continue to block the frame with shims and verify the window is plumb level and square in the opening. If needed, hard shim to secure the window in place for final anchoring with screws.
10. Pump sufficient sealant into the installation holes to ensure the anchor screws will be sealed.
11. Begin to secure the frame with #10 x 2" Ph Flat Head screws taking care not to shift the frame while anchoring.
12. Inspect the frame to ensure it is plumb, level and square and trim any excess material off the shims used.
13. Apply appropriately sized closed cell backer-rod to fill any gaps between the window and the framing gap. Ensure backer-rod is set to correct depth to allow for a 2:3 depth to width ratio for proper perimeter caulking adhesion.
14. Apply sealant at frame perimeter to the waterproofing gap and tool to ensure there are no voids or holes and a continuous bead of sealant is applied.
15. Installation is complete.

## **MULL INSTALLATION**

---

Follow these instructions to install two or more windows requiring to be field-mulled.

### **Things To Know Before You Start:**

- Drip caps must be used at the head for all vertical mulled units using a nail-fin.
- Make sure to order your drip caps for all your mulled window units. (These ship loose)
- Mull clips will come pre-installed to one side of the mulled unit, take care not to damage these clips prior or during installation.
- Prior to mulling ensure all mechanical fasteners are not protruding, if some are still proud carefully file fastener head till flush. This will help ensure a even reveal when mulled correctly.
- Once the mulling process is complete and the structural sealant has cured reversing this process is difficult.

## Nail-fin Mull Application Instructions

1. Apply a 1/4" diameter bead of Dow 795 sealant or equivalent sealant in the mull clip groove and at the sealant groove. (See Figure 3)

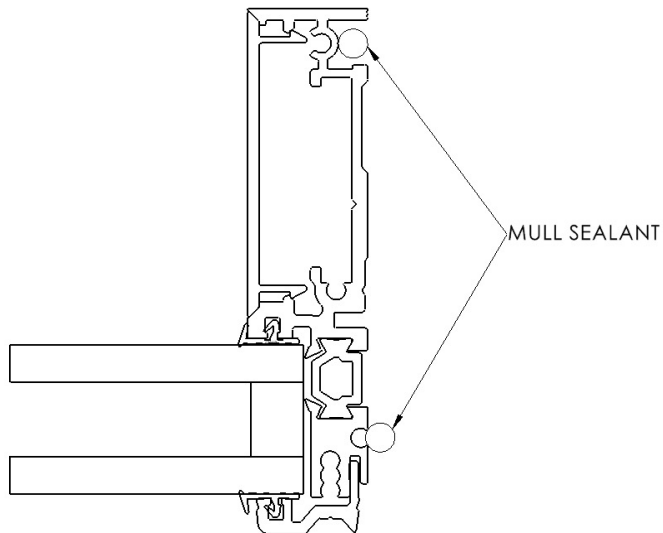

Figure 3

2. Begin to join the two (2) window units together until the frame members come into contact and the mull clip is no longer visible.
3. Verify that the reveal is even from top to bottom. If necessary, use quick clamps with tips protected, and squeeze the units together for an even reveal. Additional #10 x 1/2" joining screws shall be added between the two units, at 16" on center location, as shown in Figure 4 for units with a horizontal mull greater than 96".

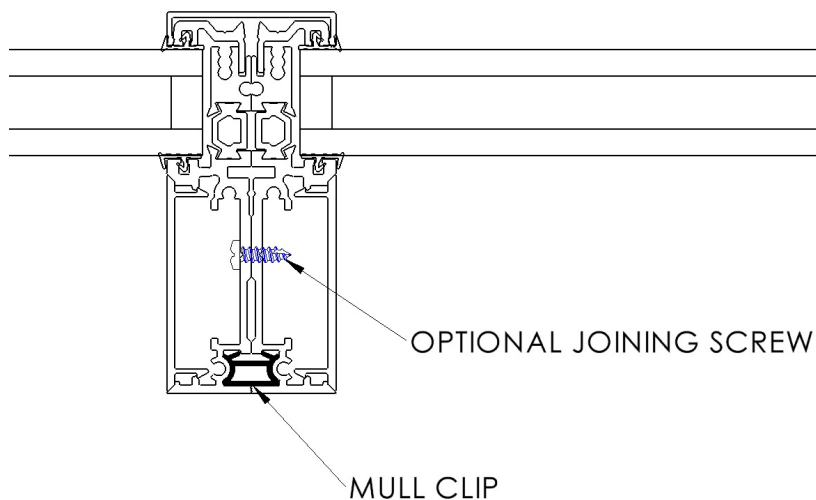

Figure 4

4. With the two windows now mullled, in the opening, shim the frame jambs at the head and sill interface to push and hold the two (2) units together. Note: Take care not to over shim causing the horizontal members to buckle or bow causing an uneven reveal on the window.
5. Locate and apply the continuous 1" beauty covers (shipped loose) to the perimeter frame. If needed, trim the length to fit. Use caution to not bend or dent the cover during installation. DO NOT use a hard mallet to install.
6. Locate and apply the continuous 2" beauty covers at each mullled joint. If needed, trim the length to fit. Use caution to not bend or dent the cover during installation. DO NOT use a hard mallet to install.
7. Seal and fill the seam created at the vertical mull on the exterior face of nail-fin. Tool and smooth out the sealant ensuring the joint is free of voids. (See Figure 5)

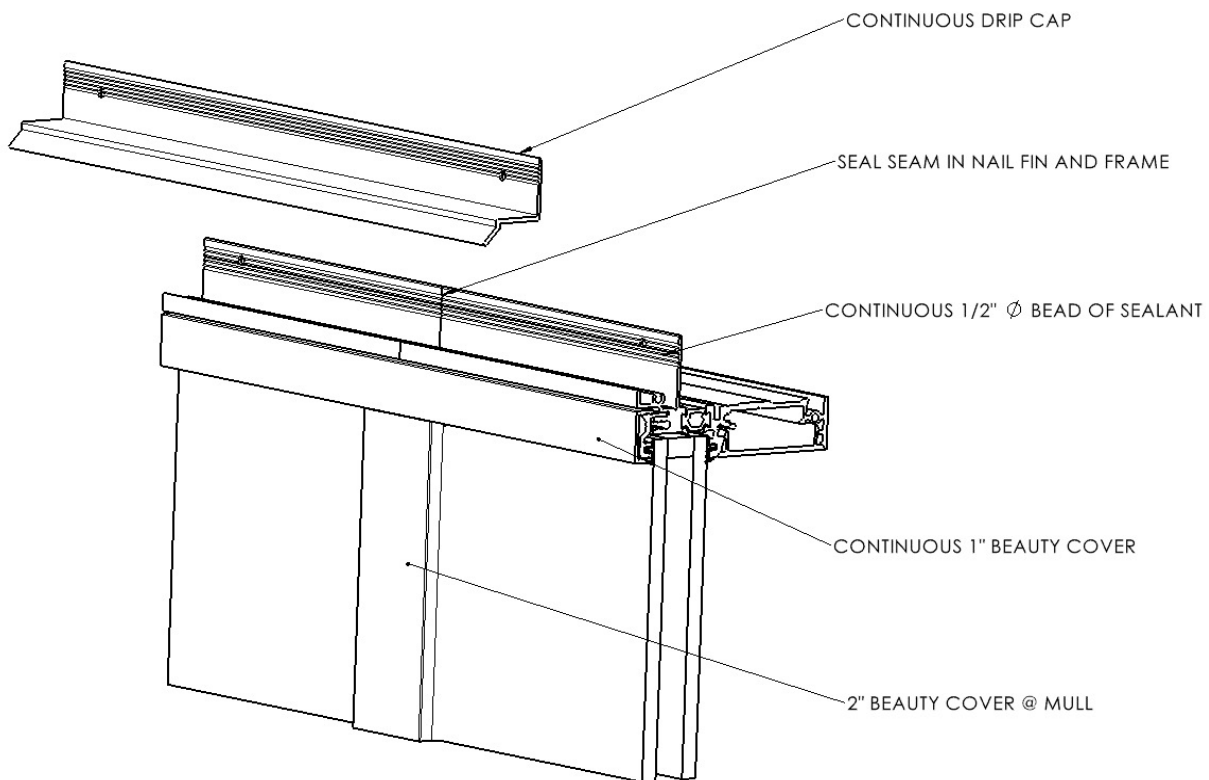

Figure 5

8. Apply a 1/2" continuous bead of sealant across the nail-fin from edge of frame opposite edge.
9. Place the drip cap onto the face of the nail-fin and secure it to the structure with #10 x 2" screws every 12" on center. To avoid any damage or distortion, do not anchor the nail-fin within 3" from any corner.



10. Seal the ends of the drip cap to the frame joint to avoid water intrusion at each end.
11. Proceed with applying the final waterproofing membrane over the drip cap and nail-fin.
12. The installation of the muller windows is complete.

## Block Frame Application Instructions

1. Approximately 1-1/2" to 2" in from the exterior face of the rough opening, apply a 1/2" bead of sealant full width of the sill opening and 4" up both jambs.

**Note: This step of properly sealing the rough opening is critical to ensure a watertight installation.**

2. With a thin pry bar, locate the edge of the interior cover to the frame joint and pry the cover off the frame. (See Figure 6)

**Note: take caution with removing the interior covers as damage can occur if care is not taken.**

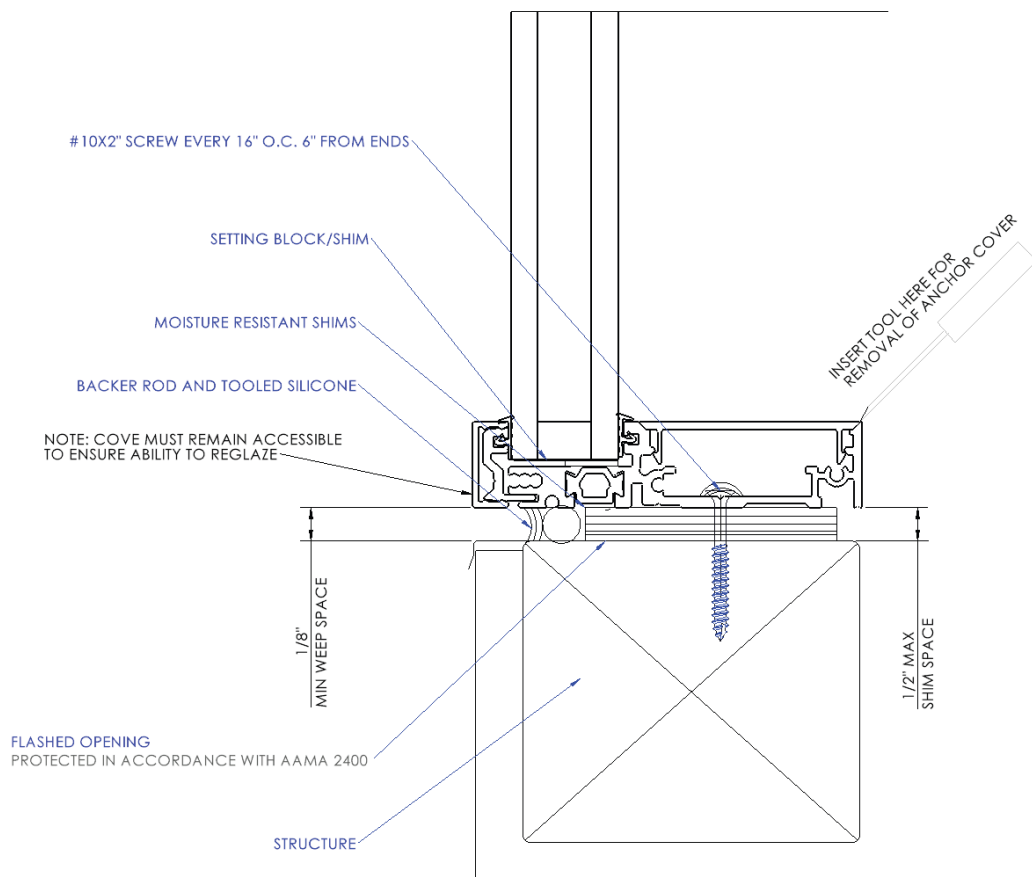

Figure 6

3. Continue removing the remaining covers from the frame exposing the anchoring channel.
4. Using the v-groove on the frame profile, drill 3/16" installation holes 6" from each end and every 16" thereafter.
5. Countersink the installation holes to accommodate a #10 Flat Head screw.
6. Apply a 1/4" diameter bead of Dow 795 sealant or equivalent sealant in the mull clip groove and at the sealant groove. (See Figure 7)

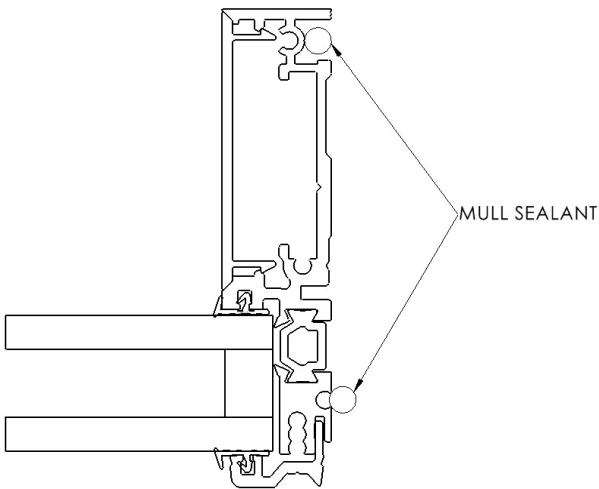

Figure 7

7. Begin to join the two (2) window units together until the frame members come into contact and the mull bar is no longer visible.
8. Verify that the reveal is even from top to bottom. If necessary, use quick clamps with the tips protected and squeeze the units together for an even reveal. Additional #10 x 1/2" joining screws shall be added between the two units, at 16" on center location, as shown in Figure 8 for units with a horizontal mull greater than 96".

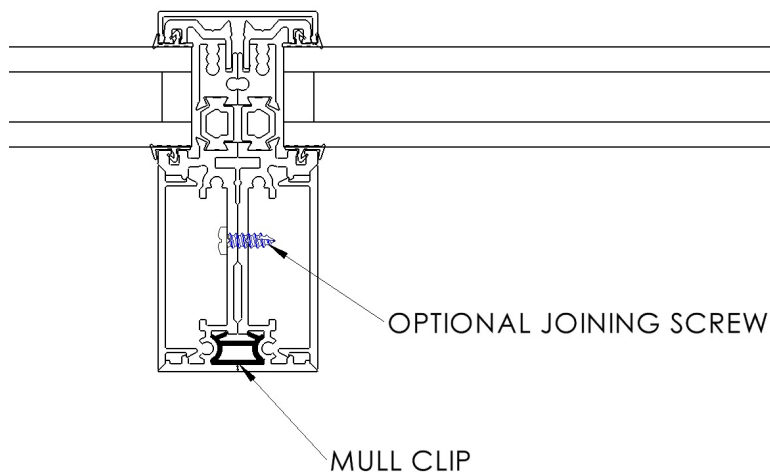

Figure 8

9. With the two windows now mulled, in the opening, shim the frame jambs at the head and sill interface to push and hold the two (2) units together.

**Note: Take care not to over shim. Over shimming can cause the horizontal members to buckle or bow resulting in an uneven reveal around the window.**

10. Locate and apply the continuous 1" beauty covers (shipped loose) to the perimeter frame. If needed, trim the length to fit. Use caution not to bend or dent the cover during installation. Do not use a hard mallet to install as it can damage the product.
11. Locate and apply the 2" beauty covers at each muller joint. The vertical covers will run from the top of sill continuously to the bottom of the head. The horizontal covers will be interrupted by the vertical covers and the jambs. If needed, trim the length to fit. Use caution not to bend or dent the cover during installation. Do not use a hard mallet to install as it can damage the product.
12. Continue to block the frame with shims as needed and verify the window is plumb level and square in the opening. If needed, hard shim to secure the window in place for final anchoring with screws.
13. Pump sufficient sealant into the installation holes to ensure the anchor screws are completely sealed.
14. Begin to secure the frame with #10 x 2" Ph Flat Head screws taking care not to shift the frame while anchoring.
15. Inspect the frame to ensure it is plumb, level and square and trim excess material off shims used.
16. Apply appropriately sized closed cell backer-rod to fill window to the framing gap. Ensure the backer-rod is set to the correct depth to allow for a 2:3 depth to width ratio for proper perimeter caulking adhesion.
17. Apply sealant at the frame perimeter to the waterproofing gap and tool to ensure a continuous bead of sealant is applied and there are no holes or voids.
18. Installation is complete.

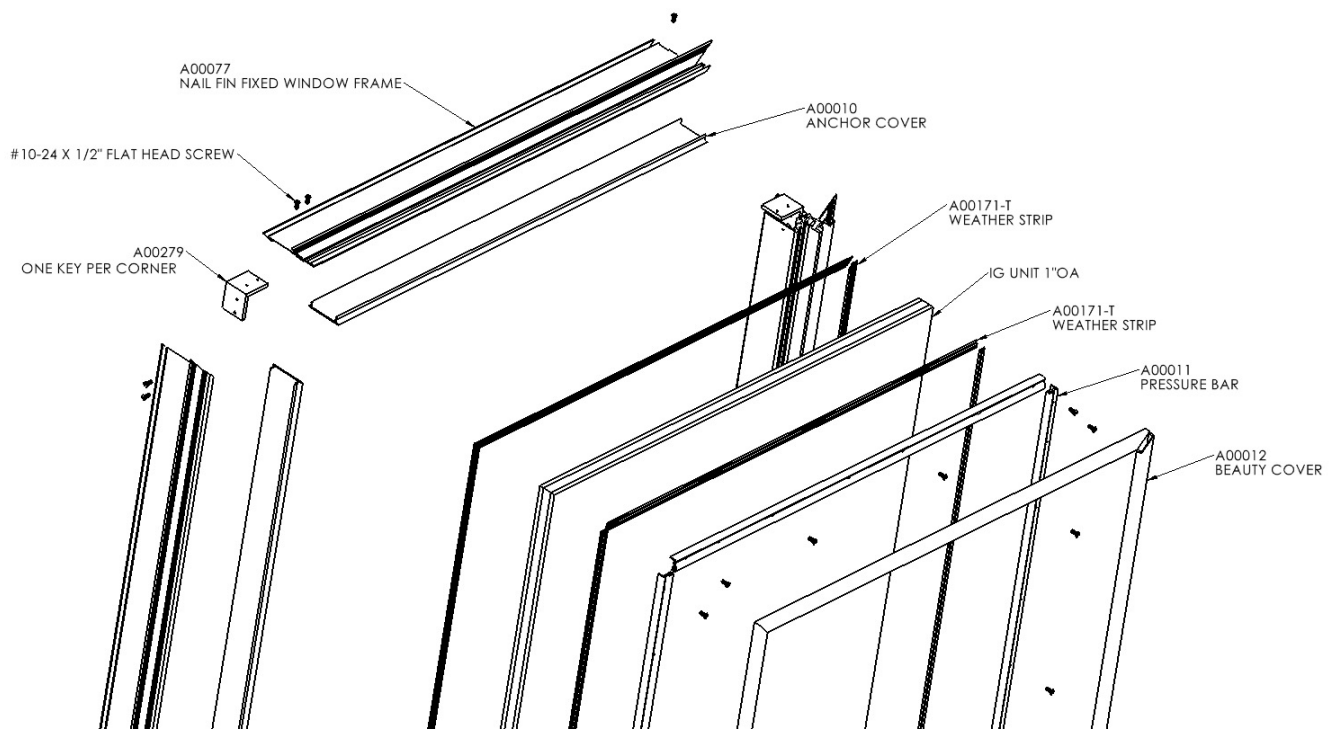

Figure 9 - Magnified Fixed Window Components



## T-bar Frame and Knock Down Frame Assembly Instructions

1. This section covers the assembly of larger units that are shipped knocked down (as unassembled component parts), or that use T-bars to form larger units prior to installation. After assembly of units, refer to the installation portions of these instructions above to properly install the assembled units.
2. On a flat, clean, and smooth surface, lay out the head, jambs, sill, and any vertical and/or horizontal T-bars in the same configuration as they will be in when installed. Verify that all required frame parts are the specified and correct length and type.
3. Locate all assembly keys and brackets. Verify that the correct quantity and type of keys and brackets have been supplied for each joint type in your unit. See Figures 10, 11, and 12 below for a magnified view of each joint type and the associated hardware. Vertical T-bars meeting the perimeter frame will require a wind load bracket at each end of each vertical T-bar (A00282 and A00286). Horizontal T-bars will utilize two different brackets, one for when the horizontal bar meets a vertical T-bar (A00530), and a second for when the horizontal T-bar meets the perimeter frame (A00280 and A00281). Part A00530 should be pre-installed into the horizontal T-bars prior to assembly using #10 x 3/4" screws.

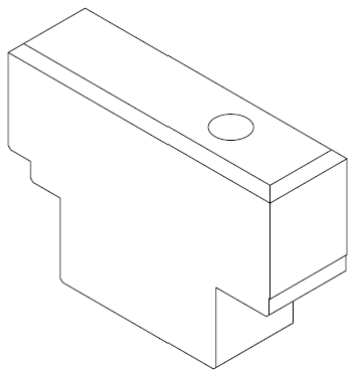

Figure 10 (A00282)

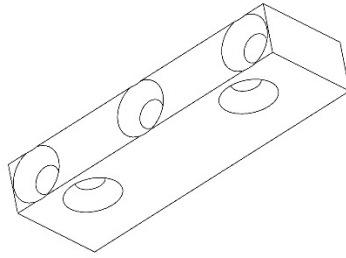

Figure 11 (A00530)

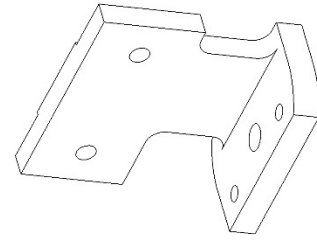

Figure 12 (A00280 & A00281)

4. On a flat, smooth, and clean surface, assemble the window wall unit starting from the sill and working up. Insert the wind load brackets for each vertical T-bar and lock into location. Verify that the center-line of the bracket is at the correct location for the center-line of the vertical T-bar and lock into place using the #10 x 1/2" locking screw.
5. Slip the Vertical T-bars over each wind load bracket, and secure in location using (4) #10 x 2" screws through the pre-drilled holes. Repeat this process for the head. For applications where a large vertical load will be required, such as transom over a patio door, the high vertical load screw must also be used to prevent sag or separation of the perimeter frame and T-bar. (See Figure 13).

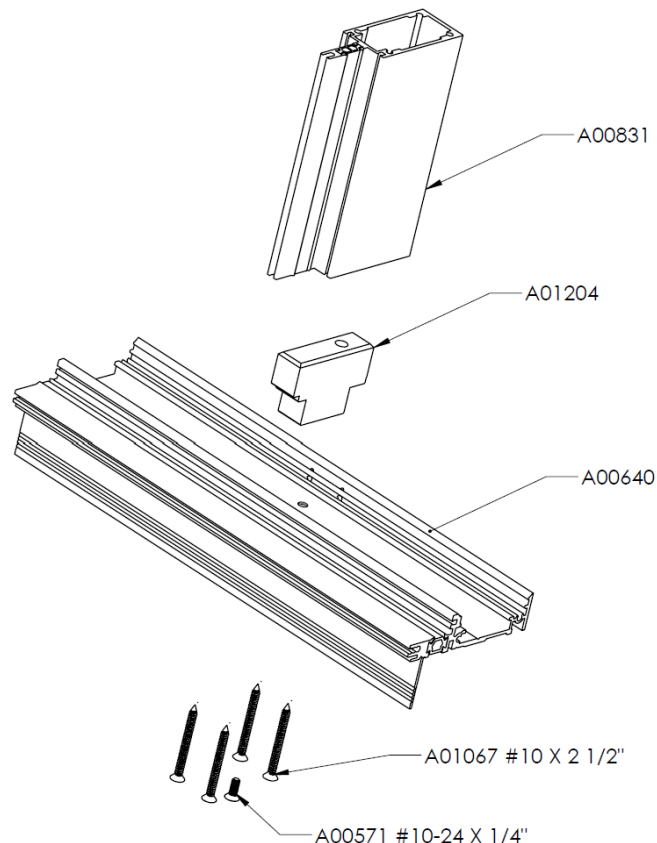

Figure 13

- Place each of the horizontal T-bars between the vertical T-bars as pictured in Figure 14. The open side of the horizontal T-bar with the pre attached brackets should be facing toward the sill (which will be facing down when the product is finally installed). Secure each end into location with (3) #10 x 1 1/4" screws through the pre-attached brackets into the pre-drilled holes on each of the vertical T-bars. (See Figure 14).

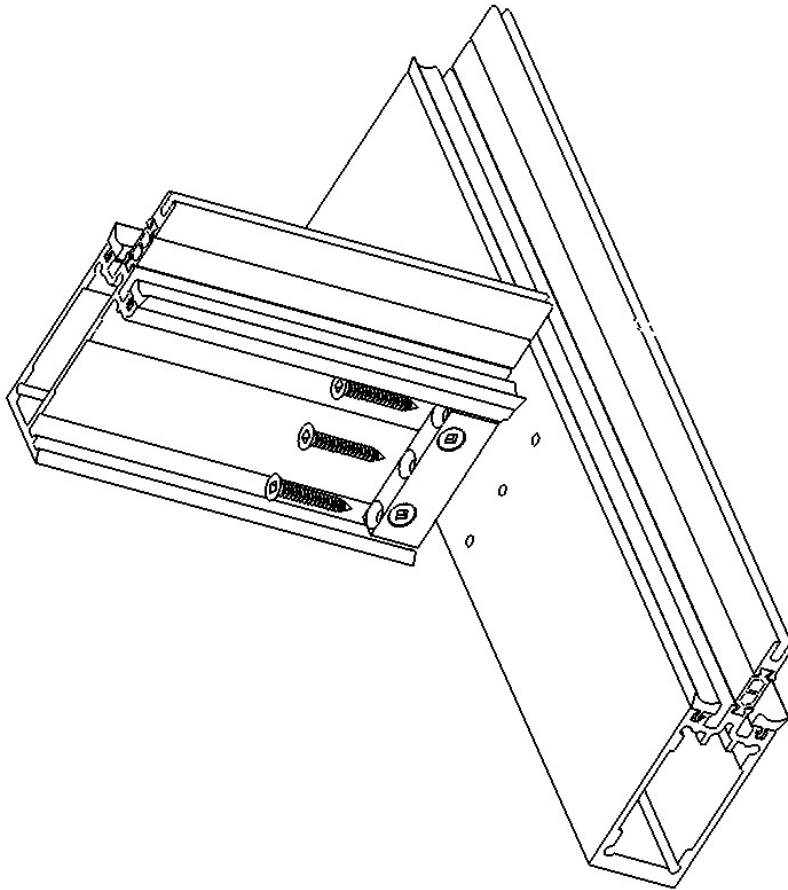

Figure 14

- Assemble the corners of the perimeter frame using the two keys and #10 x 5/8" screws. Apply a generous coat of Dow 795 sealant or equivalent to each mitred face. For perimeter frames with a nail fin, an additional screw will be used on the outer corner. (See Figure 15)

**Note: This step of properly sealing the rough opening is critical to ensure a watertight assembly.**

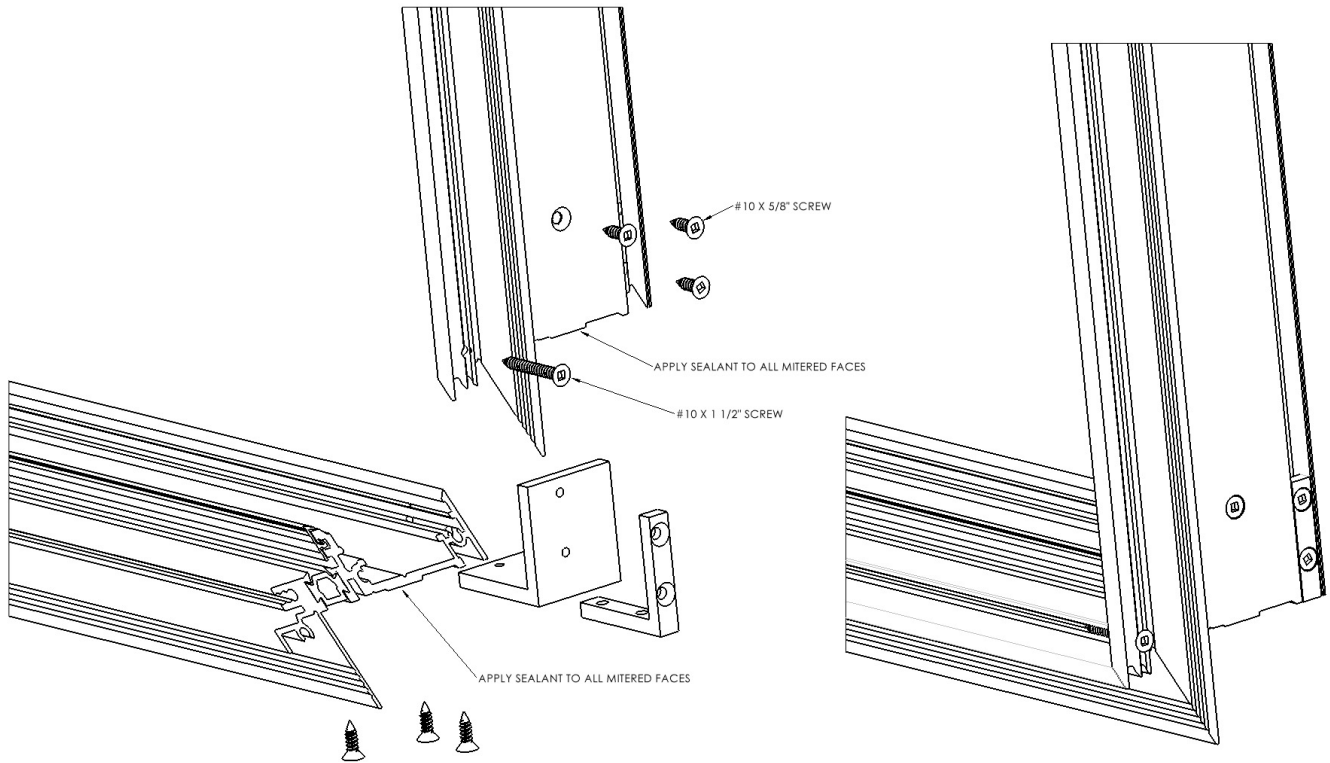

Figure 15 \*\*\*

For right angle butt glaze please refer to figure 25.

8. Insert the brackets for the horizontal T-bars into the jambs, verify that it is in the correct location, and lock into place using the locking screw. (See Figure 16).

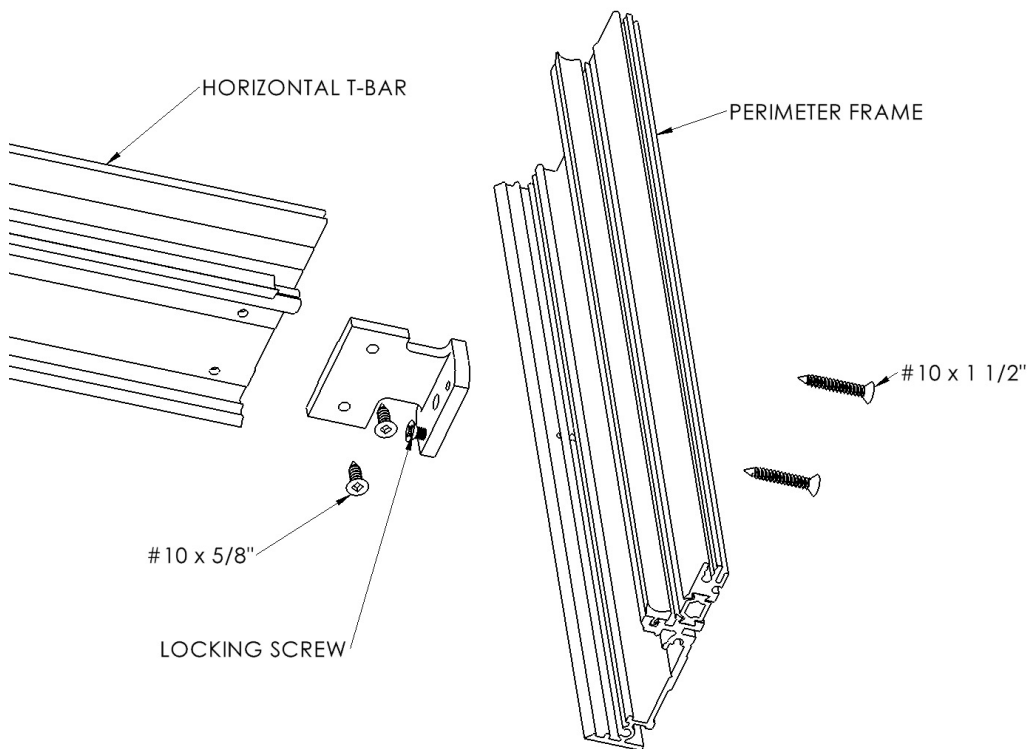

Figure 16

9. Place the Horizontal T-bar over the brackets on the perimeter frame with the open side facing toward the sill (which will be facing down when the product is finally installed). Assemble the horizontal T-bars onto the Perimeter frame from below using (2) #10 x 5/8" screws through the wind bracket and (2) #10 x 1 1/2" screws through the pre-drilled holes in the perimeter frame into the screw bosses on the horizontal T-bar. If the opposite end of the horizontal T-bar is attached to a vertical T-bar, follow the same process outlined in step 6.
10. Once all vertical T-bars, horizontal T-bars, and perimeter frame members are assembled, measure their location, and verify that they are correct prior to moving to the next steps of installation.
11. At each location where the weather strip joins at the intersection, and at each face where two frame members meet, apply a generous amount of Dow 795 sealant or equivalent and tool sealant to ensure a continuous watertight seal with no holes or voids. Apply and tool sealant over all vertical load screws and all assembly screws that penetrate the perimeter frame. (See Figure 17).

**Note: This step of properly sealing the product is critical to ensure a watertight assembly.**

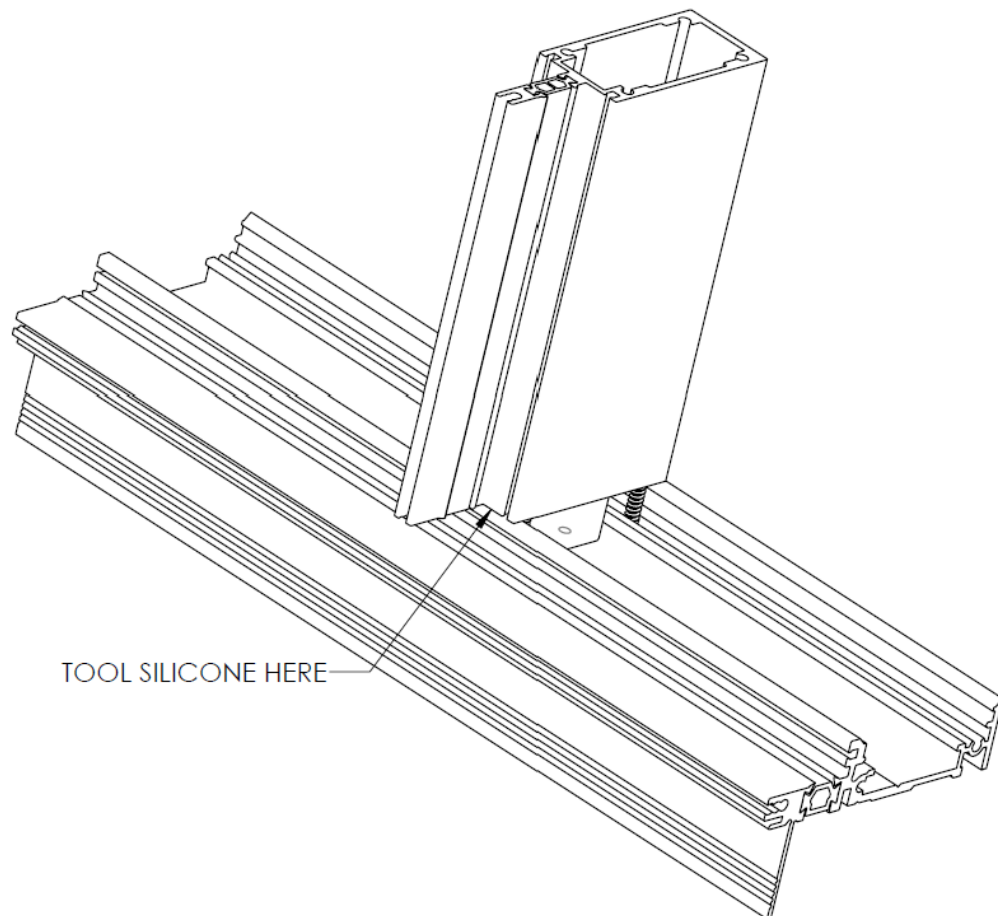

Figure 16



12. Lift the unit into the rough opening. Block the frame with shims and verify the window is plumb level and square in the opening. If needed, hard shim to secure the window in place for final anchoring with screws. If there is a block frame perimeter, then follow the Block Frame Application Instructions above. If there is a nail fin perimeter frame, then follow the Nail Fin Installation Instructions above.
13. For both block frame and nail fin frames, additional anchors are needed at each T-bar location. At each T-bar location, hard block/shim as needed and once level, drill (2) ¼" diameter holes 2" from each side of the T-bar through the anchor screw groove. Pump a generous amount of Dow 795 sealant, or equivalent, through the anchor holes and install (2) additional ¼" diameter x 3" anchors. Apply and tool additional sealant over the heads of the anchor screw. (See Figures 18 and 19)

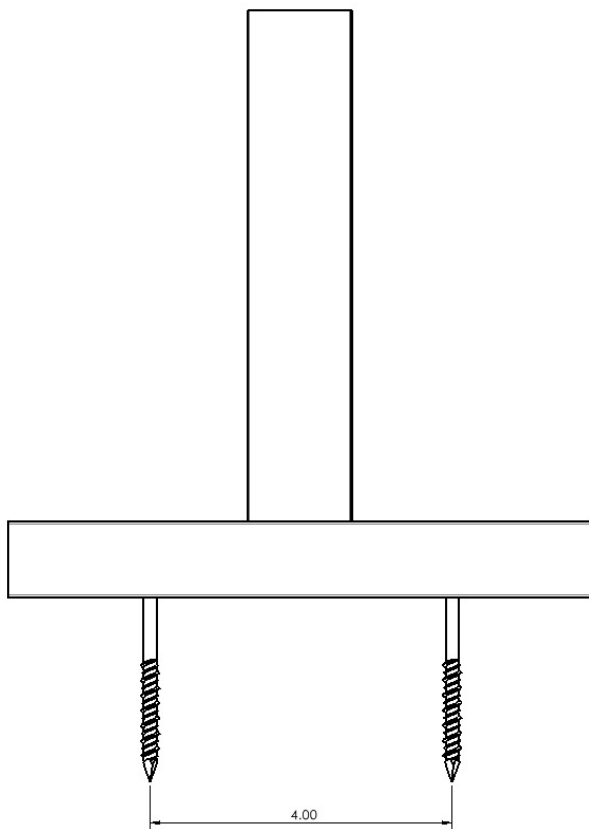

Figure 18

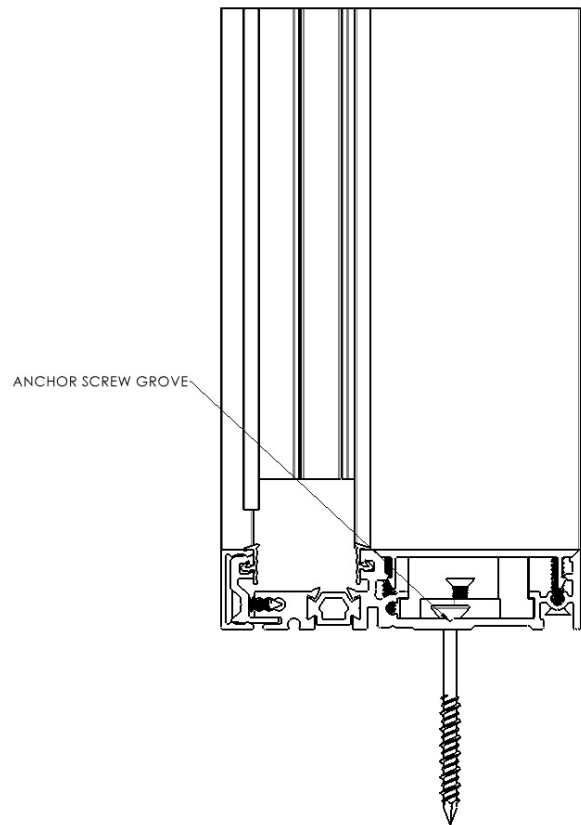

Figure 19

14. Snap in all anchor covers for the horizontal T-bars and the perimeter frame. The anchor covers for the horizontal T-bars have a notch in the snap legs to clear the wind load brackets. Care should be taken not to dent or bend the covers during installation. If a mallet is used, do not strike to covers directly as it can damage the product.

With the perimeter frame fully anchored, the installation of the Insulated Glass (IG) units can begin, starting with the bottom units first before installing upper units.

**NOTE: Clean all debris from glazing pockets.**

15. Set the Insulated Glass on two (2) pairs of setting blocks positioned at  $1/4$  points in opening as shown in Figure 20. Setting blocks are not to be placed closer than 6" from the edge of glass.

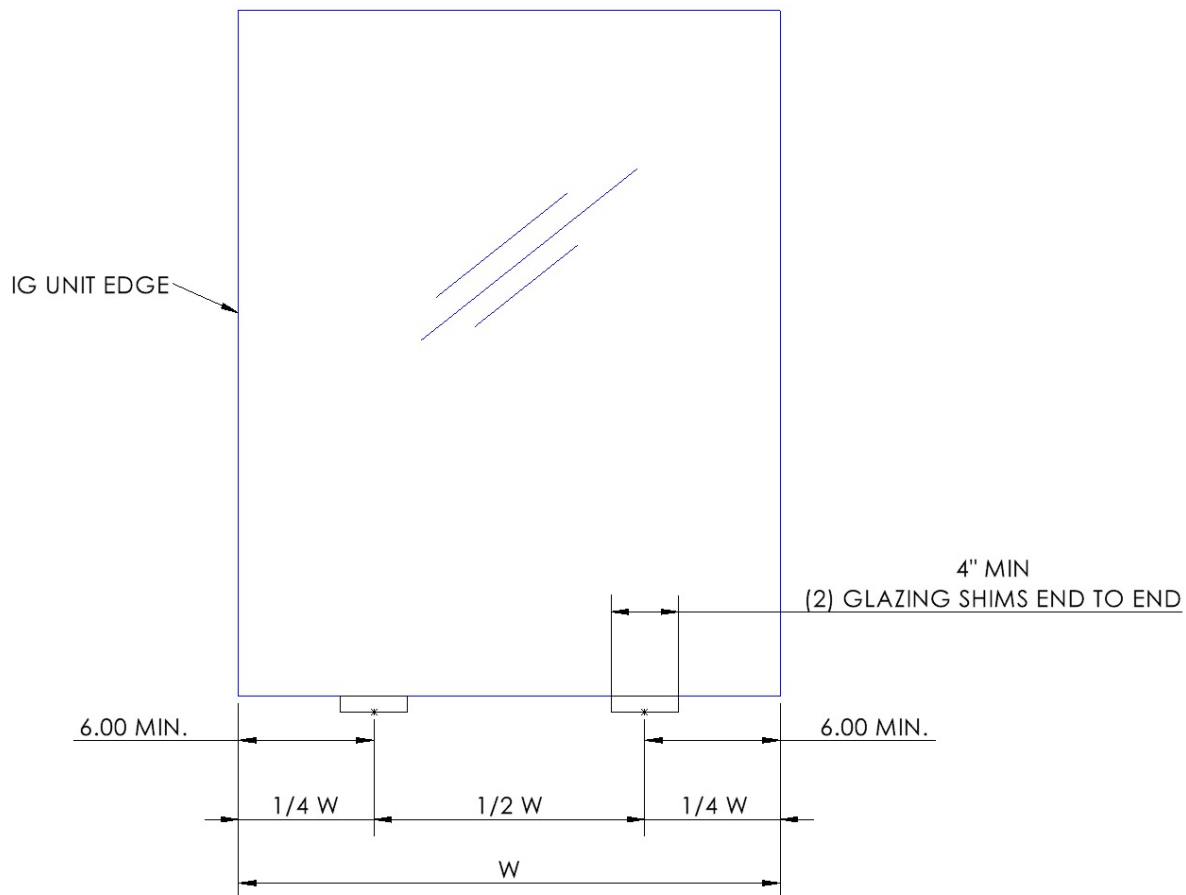

Figure 20

16. Locate the correct pressure bar for each edge. Each pressure bar should be approximately 1.5" shorter than the each of the IG unit. The perimeter pressure bars have a lip that inserts into the perimeter frame and a single weather strip. (See Figure 21). The vertical and horizontal T-bars have two weather strips. (See Figure 22).

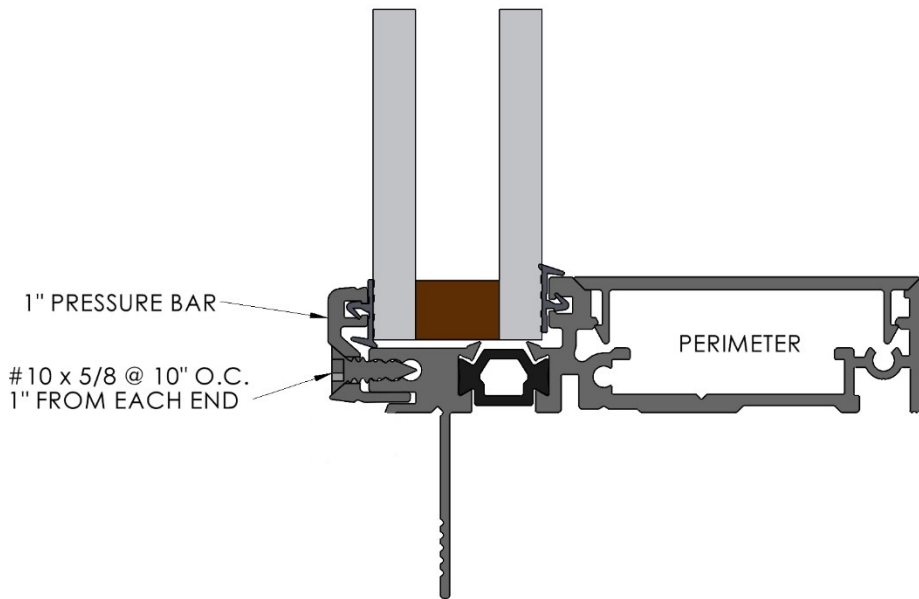

Figure 21

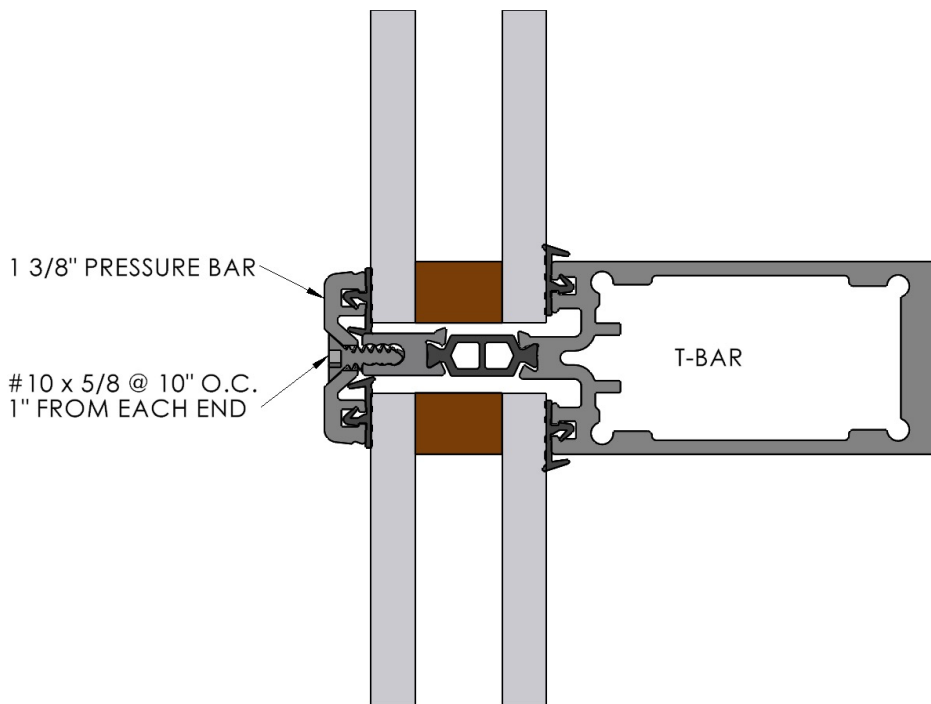

Figure 22

17. Center each bar over each edge of the IG unit, starting at the center of each bar and working to the ends, secure in location using #10 x 5/8" screws. For T-bar pressure bars, run the #10 screws down until the pressure bar just contacts the first IG unit. After the adjacent IG unit is installed, the screws must be fully tightened.

**NOTE: Ensure all pressure bar screw heads are below the face of the pressure bar. Damage to the beauty cover can occur if screw heads are too high.**

18. Continue installing the remaining IG units and pressure bars repeating steps 14-16 above.
19. Locate the correct length beauty covers for each location. The perimeter beauty covers should run continuously. The vertical T-bar beauty covers should run from the head to the sill.\* The horizontal T-bar beauty covers will be interrupted by the vertical T-bars and the jambs.\*\*
20. Snap on the beauty cover, starting at the bottom and working up. Care should be taken not to dent or bend the covers during installation. If a mallet is used, do not strike the covers directly as it can damage the product.
21. Installation is complete.

\*See Figure 23 for a magnified view of a vertical T-bar and perimeter frame intersection.

\*\*See Figure 24 for a magnified view of a horizontal T-bar, vertical T-bar, and perimeter frame intersections.

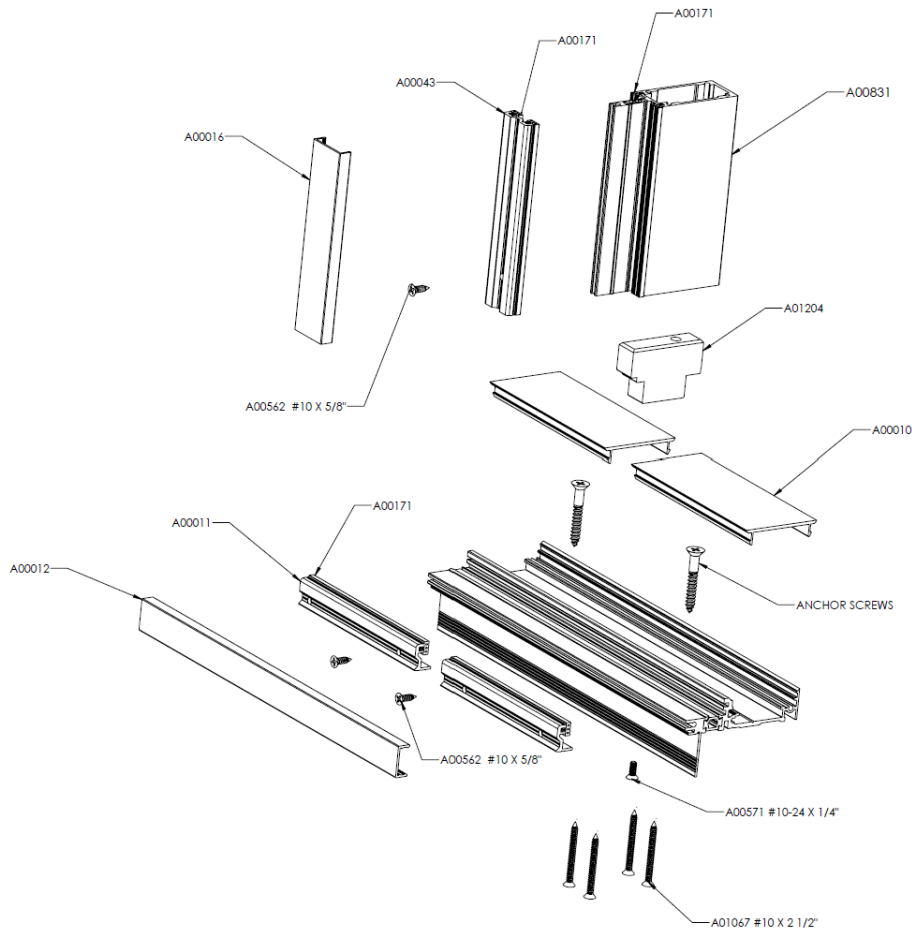

Figure 23

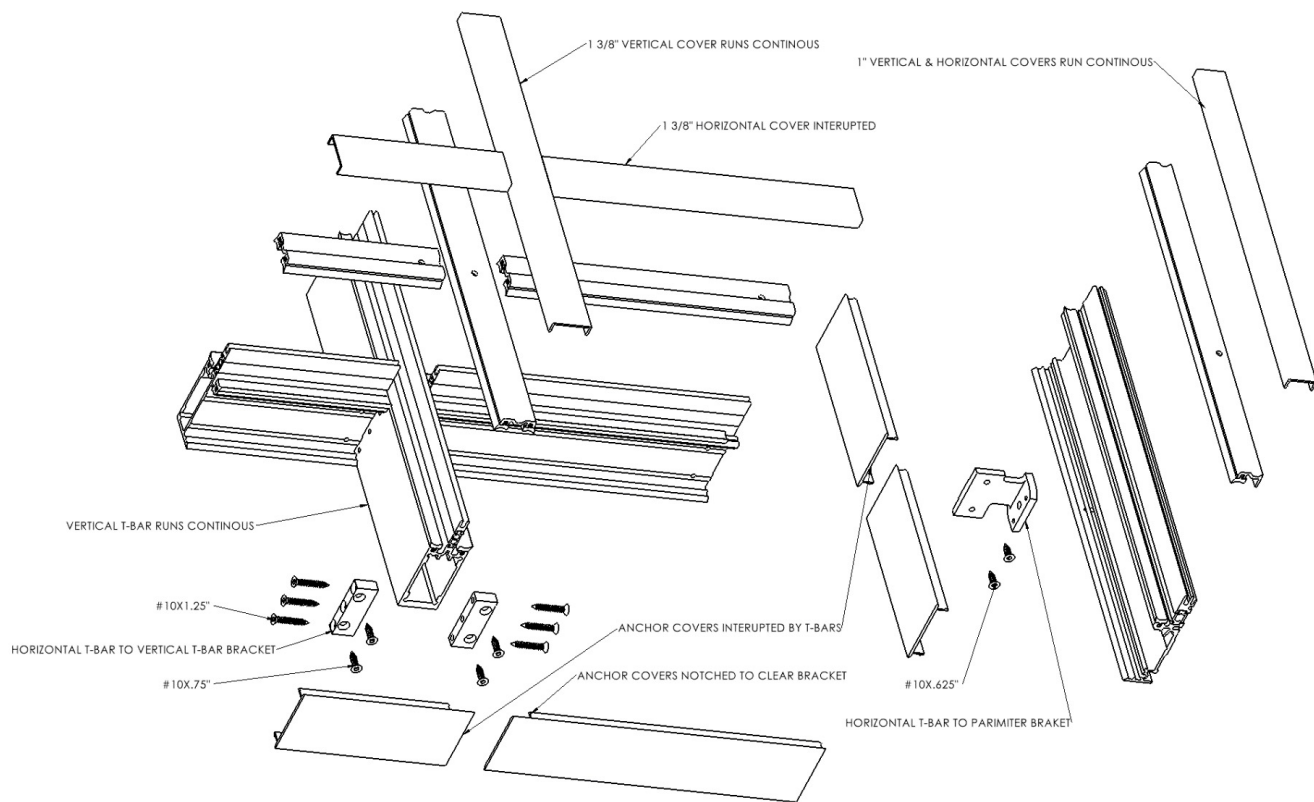

Figure 24

See figure 25 for right angle butt glazed units

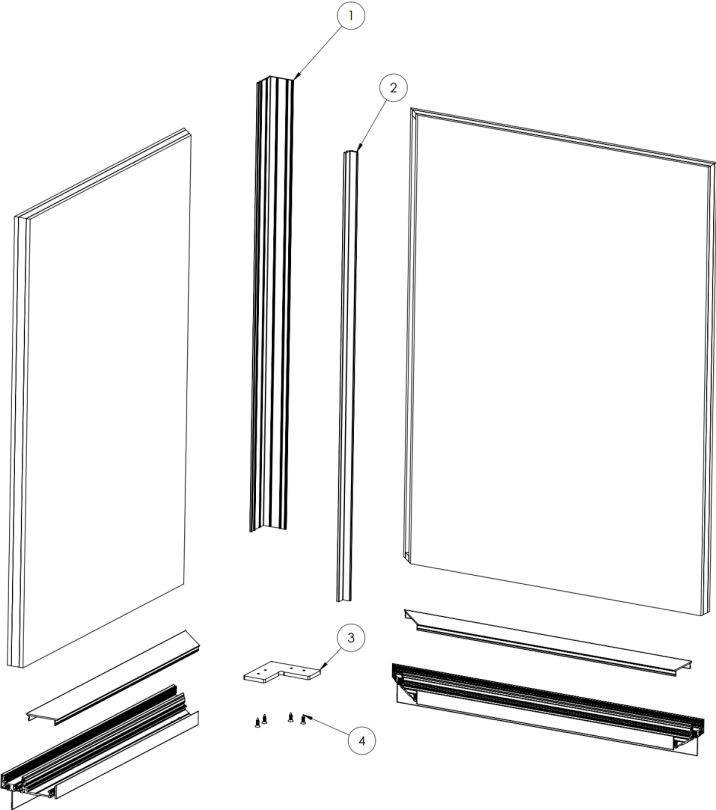

Figure 25

ITEM NO.	PART NUMBER	DESCRIPTION	QTY.
1	A00058	COVER, WINDOW WALL, CORNER, LARGE	1
2	A00109	COVER, WINDOW WALL, CORNER, SMALL	1
3	A00768	CORNER KEY, MITER, RIGHT ANGLE, FIXED WINDOW	1
4	A00562	FASTENER, #10 x 5/8", FLAT HEAD, PHIL DRIVE, SHEET METAL SCREW, T-A, 18.8 S/S	4



# GET IN TOUCH

**435 E GERMANN RD SUITE 104  
GILBERT, AZ 85297**

[www.awakewdc.com](http://www.awakewdc.com)

(833) 292-5393