

PATIO DOOR

SERIES 275

INSTALLATION INSTRUCTIONS



275 SERIES NAME

Unemployment is the greatest contributor to recidivism.

Our Patio Door products are named the 275 Series to draw attention to the fact that in 2008 when the federal unemployment rate was 5%, the unemployment rate for formerly incarcerated individuals was 27%. While surviving prison and the extremely long sentence lengths in the USA is hard enough, getting a good job when leaving prison is often the most difficult part of successfully re-entering society. Awake Window & Door Co., with your help, is creating jobs and providing meaningful second chance employment to break this recidivism cycle.

PATIO DOOR

Series 275 Patio Doors are custom manufactured specific to each order specifications. It is important that you carefully review and understand the installation instructions and any drawings supplied for your project prior to installation of any products. Disregard or failure to follow these written instructions may result in poor performance of your newly installed product including, but not limited to water intrusion, improper operation, and security issues and may void Awake Window & Door Company's limited warranties. Door products manufactured by Awake Window & Door Company should only be installed by experienced and qualified installation professionals.

STORAGE AND HANDLING

Upon delivery of your Awake Window and Door Company products, confirm that there is no damage that will affect the appearance or performance of the installed product. Inspect the product and hardware components to become familiar with them. Damaged and/or missing parts should be reported to your supplier immediately. If screens are included, they will be package separately and are to be installed after the product is finished to avoid damaging the screens.

The products must be protected before, during and after installation to prevent damage to the frame finish, hardware and or glass. Awake Window and Door manufactured products are to be kept in manufacturers packaging and stored in a dry location protected from the elements until ready for installation. If packaging becomes wet, remove, and immediately replace with dry packaging or covering to prevent damage to the product.

When handling door products, they should be transported and stored vertically on a flat even surface. All door panels are to be transported and stored upside down to avoid damage to the bottom rail weather seals. Finished product shall not be dragged off any delivery truck or dropped on floor during storage. Products should only be lifted/moved with glass cups attached directly to the glass and should not be lifted or dragged by the frame, which can cause damage.

Damage caused by improper handling and or storage is not covered by Awake Window and Door's limited warranty.

PREPARATION

Always dispose or recycle any removed door materials properly. For more information, check with your local recycling agency, the U.S. Environmental Protection Agency, or Build Reuse to locate a nearby company or organization that accepts used windows and doors.

CAUTION: Many homes built before 1978 may have been painted with lead-based paint. Removal of old doors may disturb this paint. Proper precautions must be taken to minimize exposure to dust and debris. Consult state or local authorities and/or the EPA for more information.

Verify that the number of doors ordered have been received and are manufactured to the specified size, configuration and unit numbers (which is marked in the opening). Inspect and verify the rough opening for the product which you are installing is plumb, level, and approximately 1/2" bigger in width and height than the net frame size.

Measure and inspect flooring for flat and level. If the floor varies more than 1/16" (.062") per 120-inch span or a total of 3/16" (.188") over the span of the opening width, it must be corrected prior to installation of the door. The sill should be supported or shimmed every 6" minimum. Failure to adequately install sill may result in operational issues and could result in re-installation of the sill.

Review the framing options which you are installing and prepare the frame as needed before installation.

- **Standard Nail Fin:** Pre-drill the Sill with a 3/16" drill bit 12" from each end and 24" on center through the thermal strut material of the fixed track.
- **Block Frame:** Pre-drill Head, Sill and Jambs with a 3/16" drill bit 12" from each end and 24" on center through the thermal strut material of the fixed track.
- **Window Frame:** Install the perimeter frame through the nail-fin per AAMA installation methods.

You May Need to Supply*:

- Non-compressible, moisture resistant shims/spacers
- Flashing membrane and compatible sealant
- Fasteners:
 - #8 x 1" PH Flat Head screws (Frame assembly)
 - #10 x 2-1/2" PH Flat Head screws (Nail-fin install application)
 - 3/16" Tapcon concrete anchor screws. (Sill concrete anchoring)
 - #10 x 2-1/2" Ph Flat Head screws (Block Frame install application)
- Closed cell foam backer rod/sealant backer

*All materials used in the installation must be of good quality and must be free of defects that would diminish the appearance of the product or render it structurally or operationally unsound. Installation includes the furnishing of any equipment, rigging, and materials required to install or replace the product in the proper location.

Tools Required for Installation:

- Tape Measure
- Pry bar
- Levels of various sizes
- 5 in 1 Putty knife
- Laser level (if needed)
- Dead-blow rubber mallet
- Utility Knife
- Quick Clamps
- Sealant Gun
- Suction Glass Cups
- Screw gun with:
 - #2 Phillips Driver bit
 - #2 Square Drive
- Drill with:
 - 3/16", #7, 1/4" drill bit
 - #10 Countersink bit

Note: Other construction materials may be required. Read the following instructions carefully and inspect the wall conditions before you begin.

Frame Components:

Perimeter frame shall consist of one (1) head and sill assembly, two (2) jamb assemblies, jamb fillers, and a screw pack kit.

If the total frame width exceeds 240" (20'-0") the head and sill assemblies will be supplied in two (2) sections to be sealed and joined during installation.

Panel Components:

Unless noted or otherwise requested, panel components may contain one or more options of the following:

- Operable Panels – consisting of one (1) top and bottom rail, one (1) lock stile with handle set, one (1) interlock stile, roller assemblies, and end sweeps.
- Fixed Panel - consisting of one (1) top and bottom rail, one (1) interlock stile, one (1) fixed stile and end sweep.
- Dead fixed panels - consisting of one (1) top and bottom rail, two (2) fixed stile and end sweep.
- If a bi-parting door was specified, you will also have one (1) active lead panel and one (1) inactive lead panel. The active panel will be installed to the left of center, as viewed from the exterior of the building.

WEATHERPROOFING

Rough openings must be protected with waterproofing in accordance with AAMA 2400 Installation Methods, the flashing and sealant manufacturers' instructions, and local building codes. If the product is to be set onto a cement slab, or adjacent with any masonry, a barrier must be employed to ensure there is no direct contact between the product and any cement-based products.

FRAME INSTALLATION

1. Use sawhorses or similar large flat smooth and well protected surface to assemble the perimeter frame members to avoid scratching or damaging the products.
2. Begin to seal and join the frame using Dow 795 or comparable sealant as follows:
 - Apply a continuous bead of sealant at each end of the sill for the full profile.
 - From the topside of the sill, seal the vertical joint where the interior leg of the sill meets the jamb at 90 degrees. (See Figures 1 & 2).
3. Mechanically fasten each corner with #8 x 1" PH Flat Head screws and tool the sealant into both areas to ensure the seal is complete.

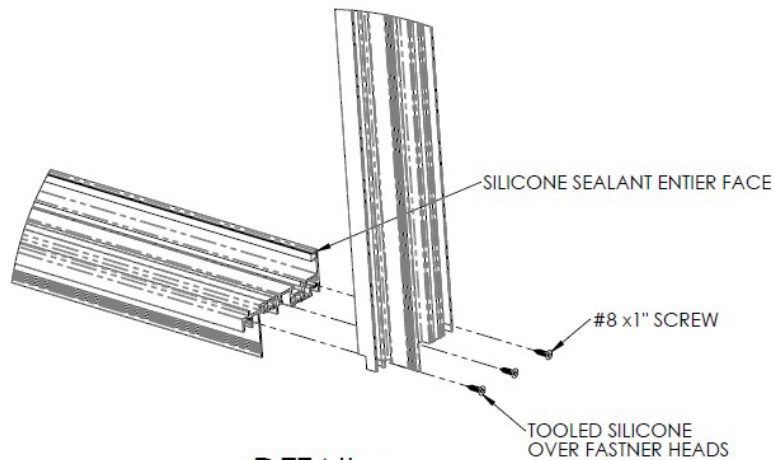

Figure 1

DETAIL U
SCALE 1 : 4

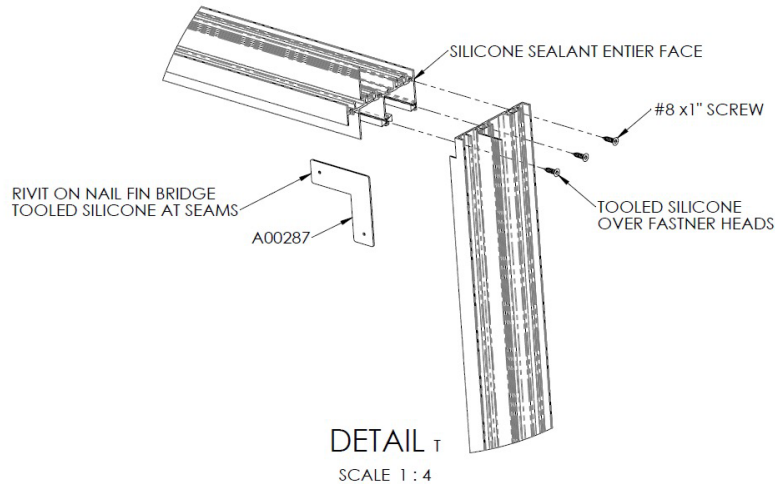

Figure 2

4. If the frame is being set on concrete, use a 5/16th drill bit for minimum 3/16" Tapcon anchor screws so that the Tapcon will grab. If the product is to be set onto a cement slab, or adjacent with any masonry, a barrier must be employed to ensure there is no direct contact between the product and any cement-based products.

Note: If you choose to drill the anchor holes into the concrete while the frame is still in place, you must vacuum the debris from the top of the sill as well as from below the sill to ensure that the caulking and or roller assemblies do not get contaminated.

5. If the substrate is wood, with a waterproofing membrane or flashing applied, apply a generous amount of appropriate and compatible sealant at each mark where an installation anchor screw will penetrate the waterproofing.
6. With the sill assembly removed, and clean from debris, apply a 1/2" continuous bead of sealant to the floor from jamb to jamb along the exterior edge of the mark previously applied at the sill. The sealant should be applied in a U-shape to ensure a proper and complete water-barrier has been accomplished across the full width of the sill opening, and at least 6" up each side. (See Figure 3).

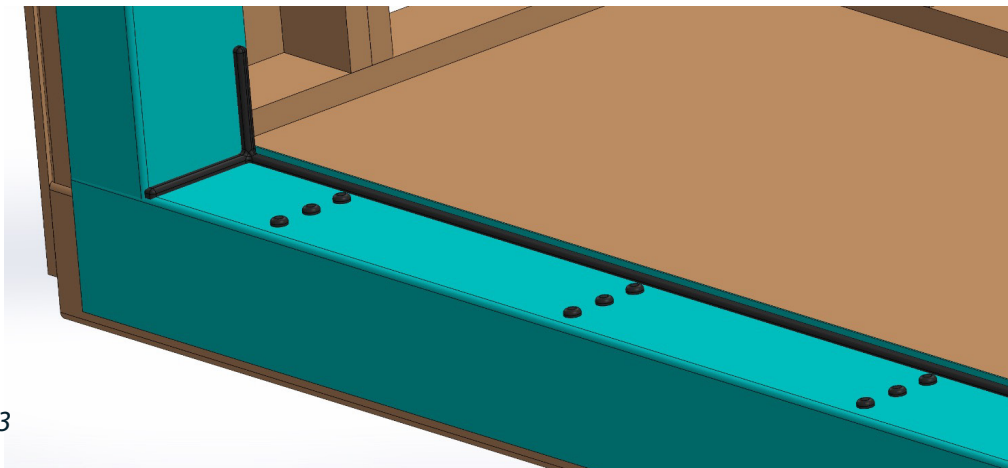

Figure 3

7. Inspect the sill where it encounters the surface of the substrate below. Look for and mark any gaps that will need to be shimmed or filled or humps that will need to be removed prior to final installation. The final installation requires that the sill be level and supported across the full span for proper operation.
8. After dry fitting the frame assembly, ensuring the fitment is adequate, and marking the screw holes and frame location, remove frame assembly and set aside.
9. Remove all debris from the floor and clean thoroughly. Then apply a 1/2" continuous bead of sealant to the floor from jamb to jamb along the exterior edge of the mark previously applied to the floor. Run a heavy bead of sealant vertically up the wall, approximately 3" up from the floor.

Note: This step is critical to ensure that the area is sealed and the installation is watertight.

10. Where the screws penetrate the flashing or waterproofing membrane, pump sealant into holes prior to inserting screws to ensure a proper seal.

Standard Nail-fin

11. Apply a 1/2" continuous bead of sealant to the interior face of the nail-fin full perimeter.
12. Set door frame into the flashed opening ensuring that the nail-fin makes full contact with the opening.
13. Check that the frame is plum, level and square in the opening and shim as needed. The sill must be level and supported across the full span for proper panel operation.
14. Anchor the door frame nail-fin to the structure with #10 x 2-1/2" screws every 16" on center. To avoid any damage or distortion, do not anchor the nail-fin within 3" from any corner.
15. Apply continuous corner bridges (supplied) and seal completely from the exterior side.

Block Frame

16. Center the frame in the waterproofed opening and temporarily secure it to the rough opening with screws as needed to hold the frame safely in place.
17. Check that the frame is plum, level and square in the opening and shim as needed. The sill must be level and supported across the full span for proper panel operation.
18. Begin to secure the frame with #10 x 2-1/2" Ph Flat Head screws taking care not to shift the frame while anchoring.
19. Inspect the frame again to ensure it is plumb, level and square and trim excess material off any shims used.

PANEL INSTALLATION

1. Locate the active lead panel and insert into the installed frame.
 - XO configuration - place lead panel at the left of the door system.
 - OX configuration - place lead panel at the right of the door system.

Note: If a bi-parting OXXO door is being installed, you will have one (1) active lead panel and one (1) inactive lead panel. Locate the active lead panel and install in accordance with the XO or OX configuration you are installing.

2. From the exterior of the building, facing the panel with the locking handle toward the interior of the building, lean the top of the panel into the innermost head track and lower the panel straight down onto the sill assembly.
3. Position the active lead panel to allow the fixed panel interlock to overlap. Ensure that the fixed panel is a few inches away from the jamb with the interlocks overlapping each other. Lean the top of the panel into the corresponding head track and lower the panel straight down onto the sill assembly.
4. With your hand on top of the fixed interlock and the ball of your foot on the bottom, gently push the fixed panel into the jamb pocket.
5. Identify and install the lock strike plate to lock the jamb. Move the lead panel close to the jamb and mark the engagement and disengagement of the lock handle on the jamb. Place the lock strike plate onto the jamb and mark the screw hole locations.
6. Drill four (4) 3/16" clearance holes at the marked locations of the strike plate. Anchor the lock strike to the jamb with #10 x 2-1/2" PH Flat Head screws. Shim as needed to avoid bowing the frame. For Bi-part conditions use #10 x 1/2" PH Flat Head Screws (See Figure 4).

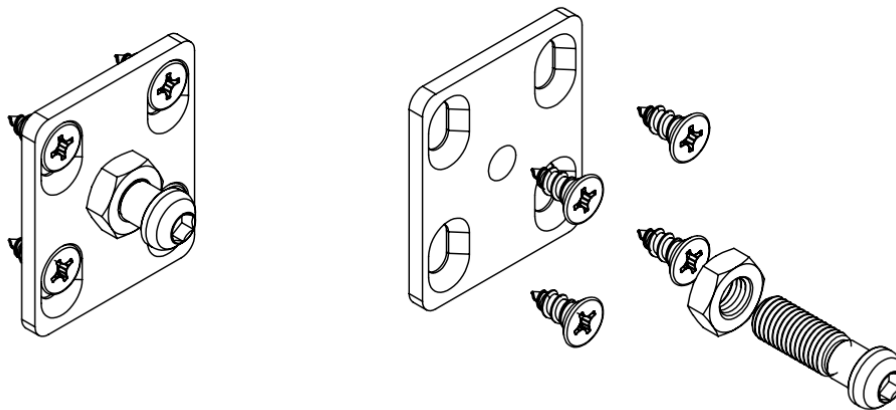

Figure 4

7. Close and lock the active panel to ensure proper engagement and disengagement. Adjust as needed.
8. The meeting interlock should line up from top to bottom and fully engage. Ensure frame and panels are plumb and square and that the fixed panel is fully seated in the jamb channel. Adjust as needed.
9. With the frame head parallel with the sill assembly, secure the fixed panel. Position the fixed clip into the head, using clip pre-drilled holes as a guide, drill clearance holes for assembly screws. Anchor the fixed clip to the frame head with a pair of #10 x 2-1/2" PH Flat Head screws. (See Figure 5).

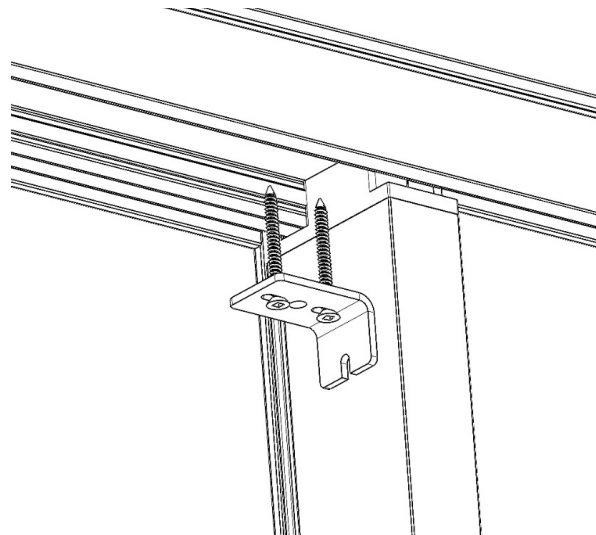

Figure 5

10. With panels in final positions, locate and install the corresponding jamb fillers into their respective tracks (highlighted blue in Figure 6) and the sill anchor cover (highlighted blue in Figure 7).

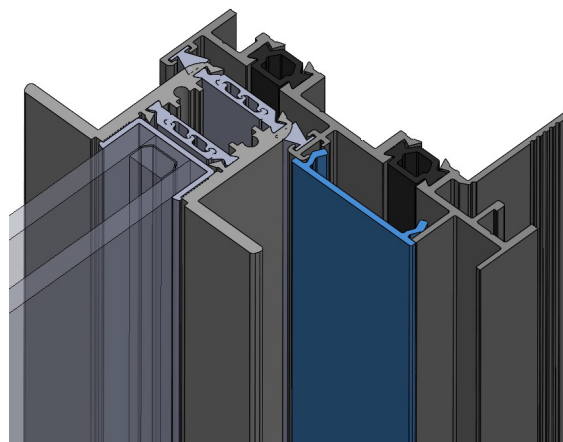

Figure 6

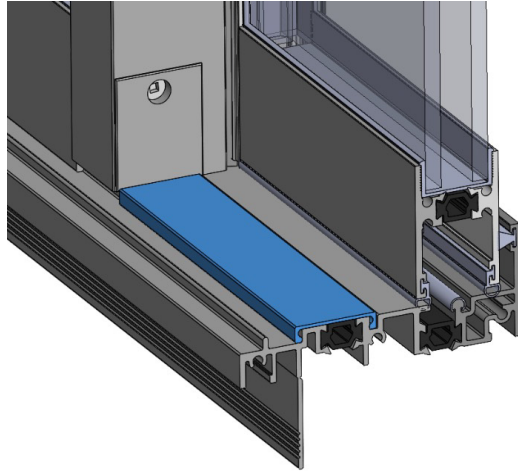

Figure 7

11. Seal the fixed panel to the frame sill, jamb, and head from the interior. Seal the frame sill to the floor by applying a continuous bead of sealant across the full length of the sill and a minimum of 6" up each jamb.
12. Before adjusting panels ensure your track is clear of any debris. At bottom of lead stile and interlocks notice a small hole at either side of the door, these holes hide the adjustment screw for each wheel assembly. By turning the adjustment screw with a philips head screw driver you can raise or lower the panel. Door operates best when a uniform gap is maintained along the edges and bottom of door.
13. The door installation is complete.

TESTING

No field testing or studies are permitted on Awake's products unless they are performed in strict compliance with the Fenestration and Glazing Industry Alliance (FGIA) Voluntary Specification for Field Testing of Newly Installed Fenestration Products, AAMA 502 and strictly comply with Awake's Testing Requirements and Conditions, available at www.awakedc.com/install-instructions). Failure to strict comply with the foregoing testing requirements will void Awake's 10-Year Limited Warranty.



GET IN TOUCH

**435 E GERMANN RD SUITE 104
GILBERT, AZ 85297**

www.awakewdc.com

(833) 292-5393